



# KD10 PN16 - PN40

*Pneumatic & Electric Globe Control Valve European std.*

Manufactured under ISO 9001 quality assurance system, the OMC **KD10** series is a top guided globe valve construction, that can accommodate a wide range of different single stage trims. **KD10** series combines the advanced modular design and a wide range of actuators to satisfy the needs of industrial applications. **KD10** valves are designed to control a broad variety of fluids, including steam, water, air and liquid or gas hydrocarbons. The top guided construction of the **KD10** provides precise plug travel over entire stroke of the valve, which minimizing vibration and increases service life.



14/68/EU Directive (PED)  
14/34/EU (ATEX)



EAC Conformity  
CU TR 010 / CU TR 032



Safety Integrity Level  
IEC EN 61508 - TÜV



Fugitive emissions  
ISO 15848-1



- ◆ From DN15 to DN200 - PN16/40
- ◆ Top Guided construction to ensure plug stability
- ◆ Designed and engineered for robustness in demanding applications
- ◆ Modular design
- ◆ CEI EN 60534-6-1 Clamp and Yoke Std.
- ◆ Std. self adjusting double packing spring loaded
- ◆ Shutoff capabilities : Class IV (std.) ,V and VI

## OPTIONS

Reduced area trim to provide wide capabilities for all sizes

Hardened trims to handle high pressure drop applications

Balanced trims to handle high pressure drop & shutoff

“Quick-Change” seat ring

Low noise & anticavitation design cage

Bellows seal to meet zero emissions (ZEB20)

Bonnet for low temperature and for high temperature

Full St.Steel actuator construction

BW / SW / RTJ connections & special on request

Heating jacket



## REFERENCE STANDARDS

Quality system management certification	ISO 9001
Design std.	EN12516-2
Flange connection	EN 1092-1
Socket-Welding Ends	EN 12760
Buttwelding Ends	EN 12627
Pressure Rating	PN16 / PN40
Face to face dimension	EN 558-1
Seat tightness Class	IEC 60534-4
Positioner mounting	CEI EN 60534-6-1
2014/68/EU (PED) Certification	Modulo B + C2
Mechanical resistance calculation method	UNI EN 12516-2
Hydrostatic pressure test	EN 12266-1
Pressure / Temperature relationship	EN 1092.1
2014/34/EU (ATEX) Conformty	II 2 G Ex h IIC T6...T1 Gb II 2 D Ex h IIIC T6...T1 Db
Non-electrical equipment for explosive atmospheres Basic method and requirements	EN ISO 80079-36
Safety Integrity Level (SIL)	IEC EN 61508
Safety Integrity Level (SIL) Approval	SIL 3 - (C-IS-722133629)
Fuggitive emissions Certification	ISO 15848-1
EAC Conformty	CU TR 010 / CU TR 032
NACE	MR0175

## STD VALVE BODY CHARACTERISTICS

Style	Top entry, single seated, globe valve
Sizes	from DN15 to DN200
Pressure rating	PN16 / PN40
Design std.	EN12516-2
Flange connection	EN 1092-1- Raised Face - Phonography serrated 125-250 AARH
Face to face dimensions	EN 558-1

## STD BODY & TRIM MATERIALS COMBINATION

VALVE BODY (1)	BONNET (9)	TRIM ( 2 and 3)	TIE ROAD	NUTS	BODY GASKET (11)
Carbon steel A216 WCC	ASTM A105	ASTM A182 F316	A193 B7	A194 H2	Graphite + Stainless steel
Stainless steel A351 CF8M	ASTM A182 F316	ASTM A182 F316	A193 B8M	A194 8M	Graphite + Stainless steel

## CONSTRUCTION EXAMPLES

1. Valve body
2. Seat ring
3. Plug
6. Top Guide sliding bush
9. Bonnet
10. Stuffing box
11. Body gasket

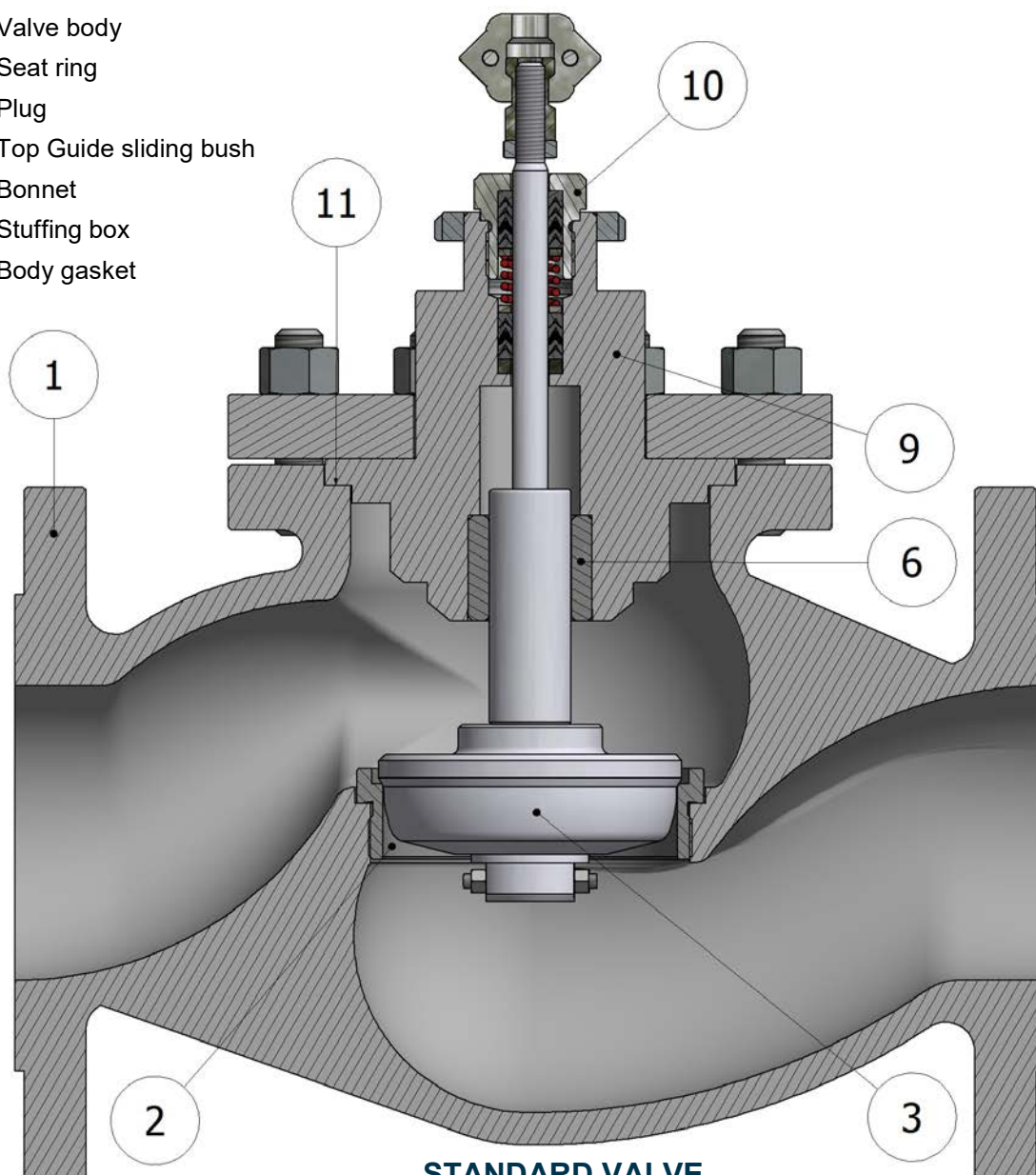

**STANDARD VALVE**

## CONSTRUCTION EXAMPLES

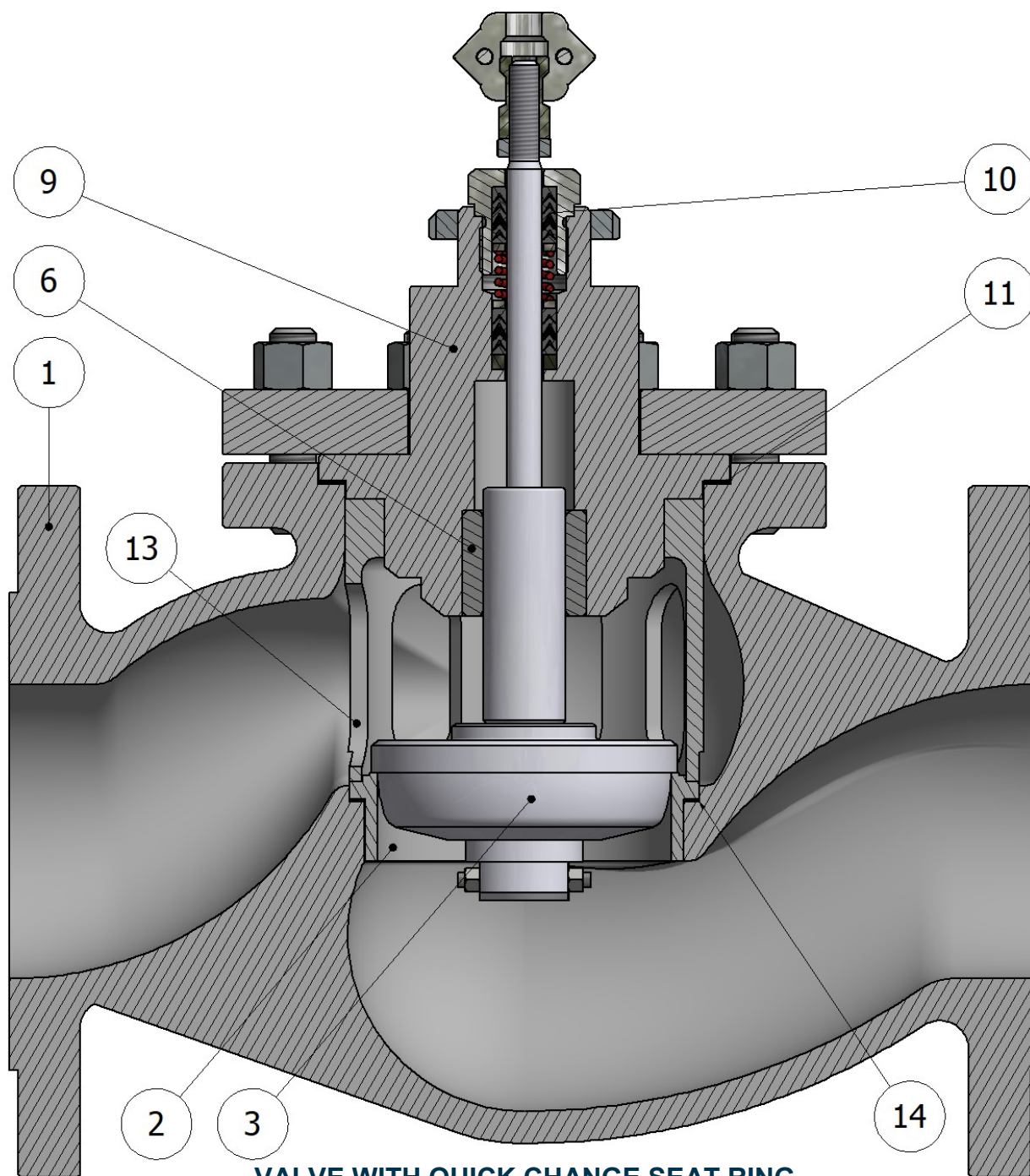

**VALVE WITH QUICK CHANGE SEAT RING**

1. Valve body
2. "Quick Change" seat ring
3. Plug
6. "Top Guide" stem
9. Bonnet
10. Stuffing box
11. Body gasket
13. Seat retainer
14. Seat gasket

Unlike the standard seat, the "Quick-Change" seat (2) is not screwed up but is blocked by the part (13). This guarantees a quick field replacement without the use of special equipment



## CONSTRUCTION EXAMPLES

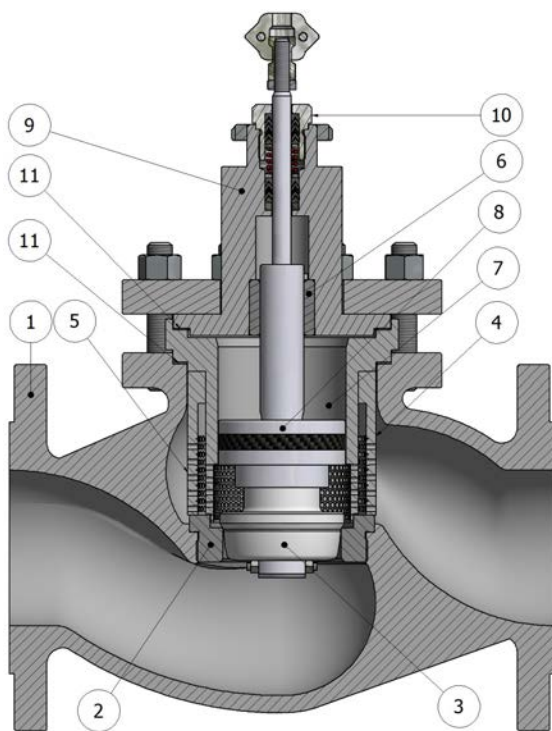

**BEALANCED TRIM VALVE  
WITH DOUBLE CAGE NOISE REDUCTION**

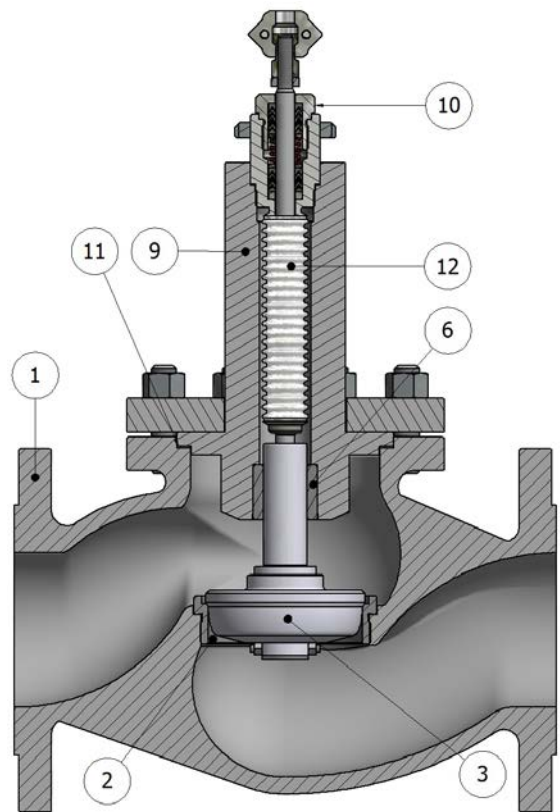

**VALVE WITH BELLOWS**

1. Valve body
2. Seat ring
3. Plug
4. 1st stage low dB Cage
5. 2nd stage low dB Cage
6. Top-guide stem
7. Balancing sleeve
8. Balancing piston
9. Bonnet
10. Stuffing box
11. Body Gasket
12. ZEB20 Bellows

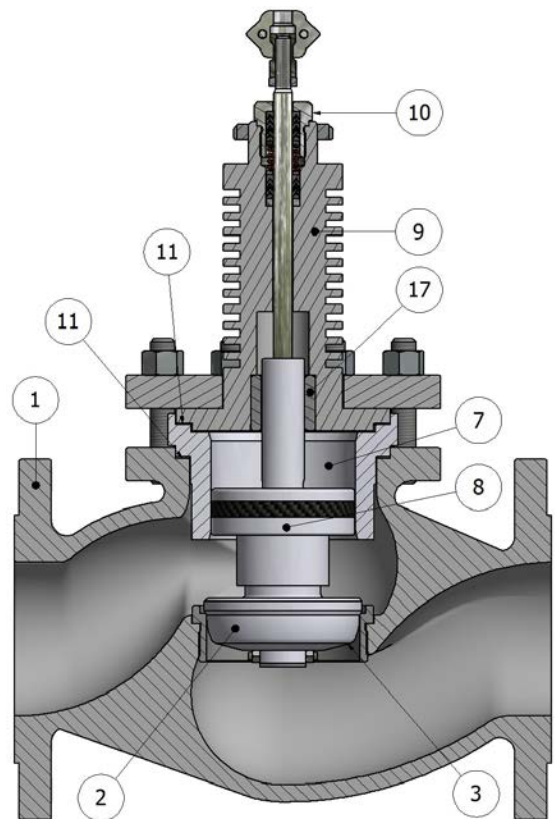

**BEALANCED TRIM VALVE WITH  
FINNED BONNET**

## WORKING PRESSURE BY CLASS STD MATERIALS (EN1092.1)

OPERATING TEMPERATURE °C	ASTM A105 / EN10273 1.0619 EN10273 1.0345 (-29° + 450°C)		ASTM A216 WCC (-29°+450°C)		A351 CF8M / EN10273 1.04408 A182 F316 / EN10272 1.4529 (-253°+600°C)	
	PN16 (bar)	PN40 (bar)	PN16 (bar)	PN40 (bar)	PN16 (bar)	PN40 (bar)
RT	16.0	40.0	16.0	40.0	16.0	40.0
100	14.8	37.1	16.0	40.0	16.0	40.0
150	14.0	35.2	16.0	40.0	14.5	36.3
200	13.3	33.3	16.0	40.0	13.4	33.7
250	12.1	30.4	15.6	39.0	12.7	31.8
300	11.0	27.6	14.0	35.2	11.8	29.7
350	10.2	25.7	12.9	32.3	11.4	28.5
400	9.5	23.8	11.8	29.5	10.9	27.4
450	5.2	13.1	6.4	16.1	10.7	26.9
500	—	—	—	—	10.5	26.4
550	—	—	—	—	10.4	26.0
560	—	—	—	—	10.3	25.7
570	—	—	—	—	10.1	25.4
580	—	—	—	—	10.0	25.0
590	—	—	—	—	9.9	24.7
600	—	—	—	—	8.9	22.7

## MATERIALS AVAILABLE ON REQUEST

Carbon steel	A352 LC2; A352 LC3; A352 LCC; A352 LCB
Alloy Carbon Steel	A217 WC6; A217 WC9
Austenitic Stainless Steel	A351 CF3; A351 CF8; A351 CF10; A351 CF3M; A351 CF8M; A351 CF10M
Ferritic Austenitic Stainless Steel (DUPLEX / SUPERDUPLEX)	A995 CD3MWCuN; A995 A6; A351 CK3MCuN; A351 CE8MC; A351 CD3MN; A351 CD4MCuN
Nickel Alloy Stainless Steel	A494 M35-1 (MONEL); A494 M35-2 (MONEL); A494 N-12MV (HASTELLOY B); A494 CW-12MW (HASTELLOY C)
TIES ROAD & NUTS	In according to the body material

## STANDARD PROTECTIVE COATING

WORKING TEMPERATURE	VALVE BODY	BONNET
from -29° to 150°C	<ul style="list-style-type: none"> <li>• Bicomponent anticorrosive acrylic primer at high resistance</li> <li>• Finish with bicomponent aliphatic acrylic enamel RAL 7021 opaque</li> </ul>	Electrolytic zinc coatings Fe/Zn 8 c1A UNI ISO 4520
from 150° to 250°C	<ul style="list-style-type: none"> <li>• Siliconic primer</li> <li>• Finish with siliconic enamel RAL 9005</li> </ul>	Electrolytic zinc coatings Fe/Zn 8 c1A UNI ISO 4520
from 250° to 400°C	<ul style="list-style-type: none"> <li>• Heat resistant siliconic primer</li> <li>• Finish with siliconic enamel RAL 9006</li> </ul>	

## PNEUMATIC ACTUATOR STANDARD PROTECTIVE COATING

### CASING AND YOKE

Polyester electrostatic epoxy powder coating - RAL 7032



**RAL 7021**

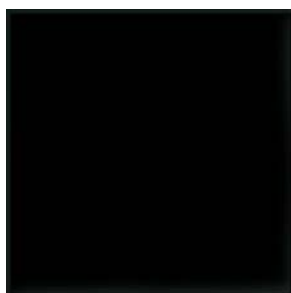

**RAL 9005**

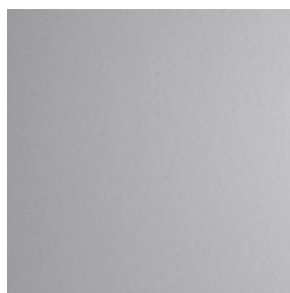

**RAL 9006**



**RAL 7032**

Colors and shades shown in the figure are indicative

## PROTECTIVE COATING ON REQUEST

Customer specification colors

Painting for see environment

Painting in according to ISO 12944



Painting in according to NORSOK M-501

NACE - FROSIO painting

Painting for see environment

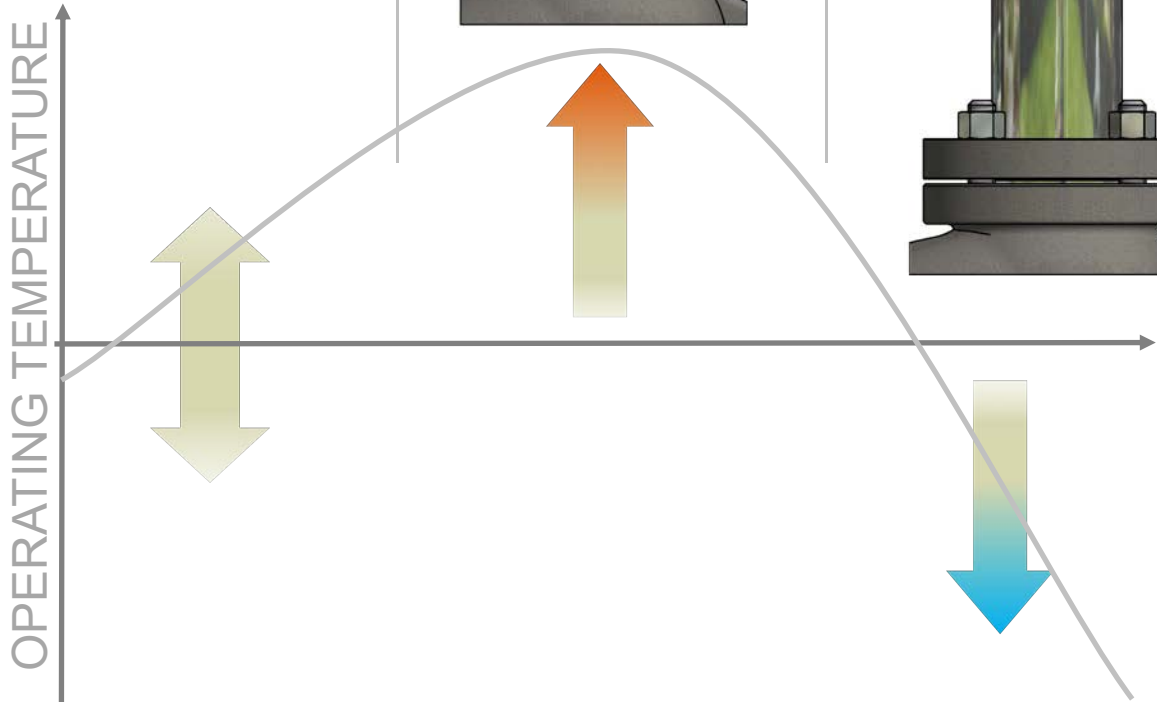

## BONNET TYPES

STANDARD	FINNED	EXTENDED
<p>The standard bonnet is cast or forged from the same or equivalent grade of material as the valve body. It is suitable for applications with temperatures between</p> <p style="text-align: center;"><b>-5°C to +200°C</b></p>	<p>The finned bonnet is cast or forged from the same or equivalent grade of material as the valve body.</p> <p>Engineered for high temperature applications the fins dissipate heat and protect valve stem packing from extreme process temperatures up to +200°C</p> <p style="text-align: center;"><b>-5°C ÷ 600°C</b></p>	<p>The extended bonnet is cast or forged from the same or equivalent grade of material as the valve body.</p> <p>To protect the stem packing the extended bonnet traps some process fluid. This provides a thermal buffer between the packing and the low temperature process fluid.</p>
		
<p style="text-align: center;"><b>OPERATING TEMPERATURE</b></p> 		
	<b>-196°C ÷ 220°C</b>	



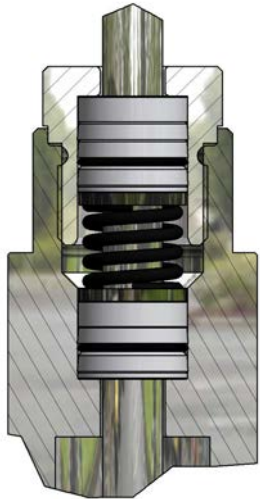
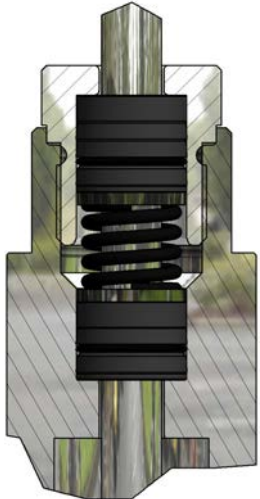
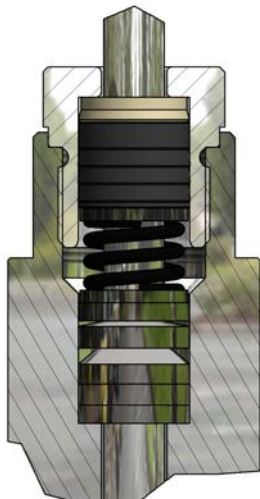
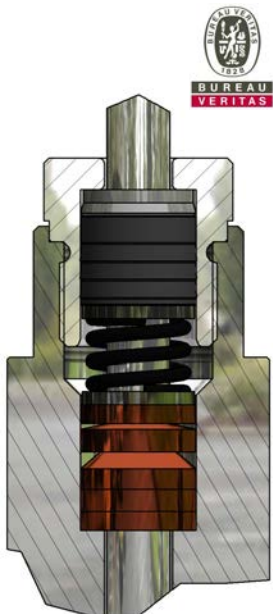

## PACKING TYPES - VALVES FROM DN15 UP TO DN100

LP200	SP200	HP300	ECOPACK 1
<p>It consists of a series of energized V ring pack in Virgin PTFE and FKM, especially used with Oxygen and Cryogenic applications.</p> <p>Self-adjusting and maintenance free.</p>	<p>It consists of a series of energized V ring pack in PTFE base &amp; FKM 75 Shore. Suitable for low &amp; medium temperature application.</p> <p>Self-adjusting and maintenance free.</p>	<p>Directly in contact with the medium it consists of a series of energized V ring pack in Graphite and PTFE. Especially used for high temperature applications.</p> <p>Self-adjusting and maintenance free.</p>	<p>Made of a series of energized V ring pack in Graphite/PTFE. <b>ISO 15848-1 Certified</b> for Low emission fugitive test.</p> <p>Self-adjusting and maintenance free.</p>
			

## PACKING / BONNET TEMPERATURE CORRELATION

	LP200	SP200	HP300	ECOPACK 1
CRYOGENIC BONNET	-196÷ 180°C	///	///	--196 ÷ 180°C
EXTENDED BONNET	-90 ÷ 180°C	-90 ÷ 220°C	///	-90 ÷ 220°C
STANDARD BONNET	-5 ÷ 180°C	-5 ÷ 220°C	///	-5 ÷ 220°C
FINNED BONNET	///	-5÷260°C	-5 ÷ 400°C	-5 ÷ 400°C
EXTENDED FINNED BONNET	///	///	-5 ÷ 600°C	///

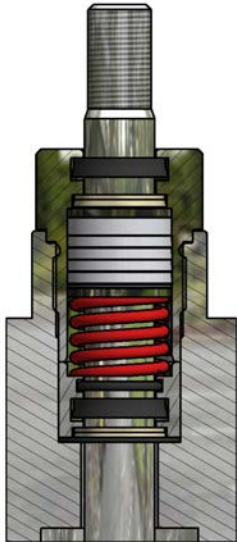
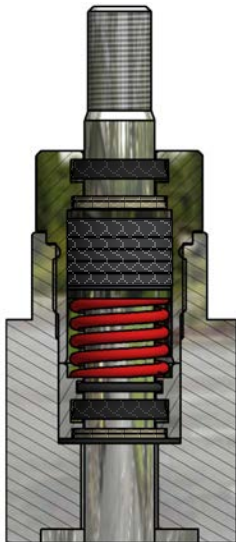
## PACKING TYPES - VALVES FROM DN125 UP TO DN200

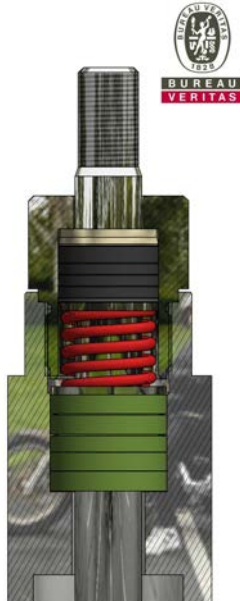
LP400	SP400	HP600	ECOPACK 2
<p>It consists of a series of energized V ring pack in Virgin PTFE and FKM, especially used with Oxygen and Cryogenic applications.</p> <p>Self-adjusting and maintenance free.</p>	<p>It consists of a series of energized V ring pack in PTFE base &amp; FKM 75 Shore. Suitable for low &amp; medium temperature application.</p> <p>Self-adjusting and maintenance free.</p>	<p>Directly in contact with the medium it consists of a series of energized V ring pack in Graphite and PTFE. Especially used for high temperature applications.</p> <p>Self-adjusting and maintenance free.</p>	<p>Made of a series of energized V ring pack in Graphite/PTFE. ISO 15848-1 Certified for Low emission fugitive test.</p> <p>Self-adjusting and maintenance free.</p>
			

## PACKING / BONNET TEMPERATURE CORRELATION

	LP400	SP400	HP600	ECOPACK 2
CRYOGENIC BONNET	-196÷ 180°C	///	///	-196 ÷ 180°C
EXTENDED BONNET	-90 ÷ 180°C	-90 ÷ 220°C	///	-90 ÷ 220°C
STANDARD BONNET	-5 ÷ 180°C	-5 ÷ 220°C	///	-5 ÷ 220°C
FINNED BONNET	///	-5÷260°C	-5 ÷ 400°C	-5 ÷ 400°C
EXTENDED FINNED BONNET	///	///	-5 ÷ 600°C	///

## ZEB20 BELLOWS FOR DANGEROUS FLUID

ZEB20 is specifically designed for industrial applications where the possible leakage of process fluid from the packing can cause environmental or personal damage and in extreme cases be hazardous to health.

The ZEB20 is manufactured by welding a bellows to the plug stem and valve bonnet. This removes potential leakage paths, while allowing full movement of the stem. The design provides total isolation of the fluid from the outside environment.

The ZEB20 also includes secondary stem seals as a safety function. These only operate in the unlikely event that a bellows ruptures. The secondary seals will provide reduced risk.

The standard of the bellows material is AISI 316L but, it is also available in other materials, including Inconel, Monel, Hastelloy, etc...

For safety critical applications the ZEB20 can be fitted with a test connection to allow the addition of feedback devices that monitor the integrity of the bellows

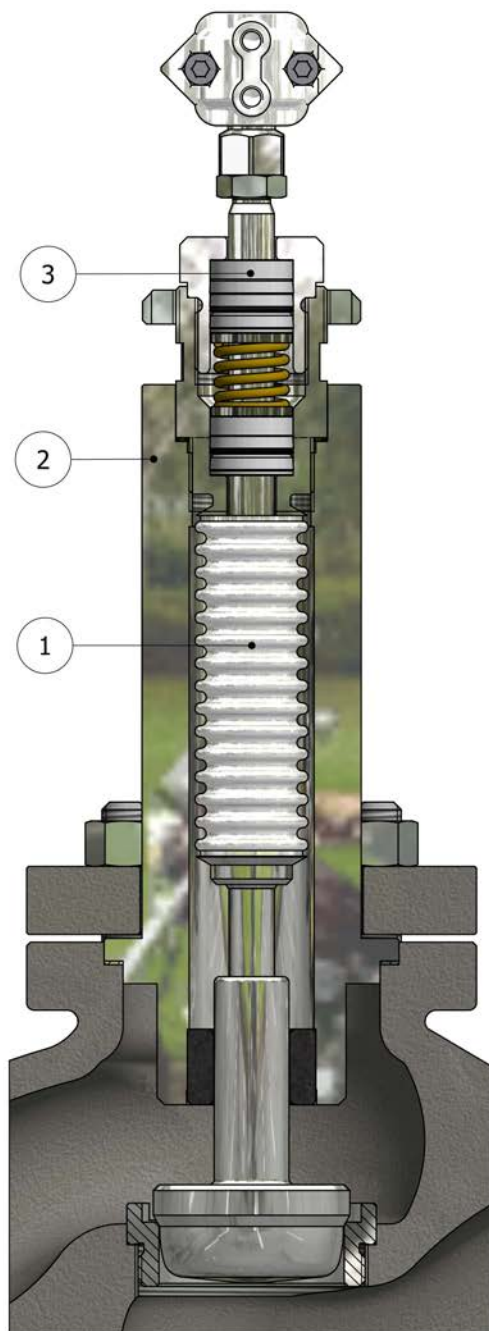

Fugitive emissions

ISO 15848-1

## ZEB20 MATERIALS COMBINATION

POS.	DESCRIPTION	STD MATERIALS	ON REQUEST
1	Bellows	AISI 316L	Inconel, Monel, Hastelloy, other materials
2	Bonnet	SP200 / SP400	LP200 / HP300 / ECOPACK 1 LP400 / HP600 / ECOPACK 2

## CONTROL CHARACTERISTICS

QUICK OPENING	LINEAR	EQUAL PERCENTAGE
<p>A valve with quick opening flow characteristic provides a maximum change in flow rate at low travels and small changes when the valve plug is near maximum. Control valves with quick opening flow characteristics are often used for on/off applications where significant flow rate must be established quickly as the valve begins to open. Consequently they are often used in relief valve applications. Quick opening valves can also be selected for many of the same applications for which linear flow characteristics are recommended.</p>	<p>A valve with linear characteristic provide a flow rate directly proportional to travel. Linear characteristics are commonly specified for liquid-level and flow-control applications.</p>	<p>In equal percentage flow characteristic, equal increments of valve travel produce equal percentage changes in the existing flow. A valve with an inherent equal percentage flow characteristic provides precise throttling control through the lower portion of the travel range and rapidly increasing capacity as the valve plug nears the wide open position. Valves with equal percentage flow characteristics are used on pressure control applications, on applications where a large percentage of the pressure drop is normally absorbed by the system itself with only a relatively small percentage available at the control valve, and on applications where highly varying pressure drop conditions can be expected.</p>

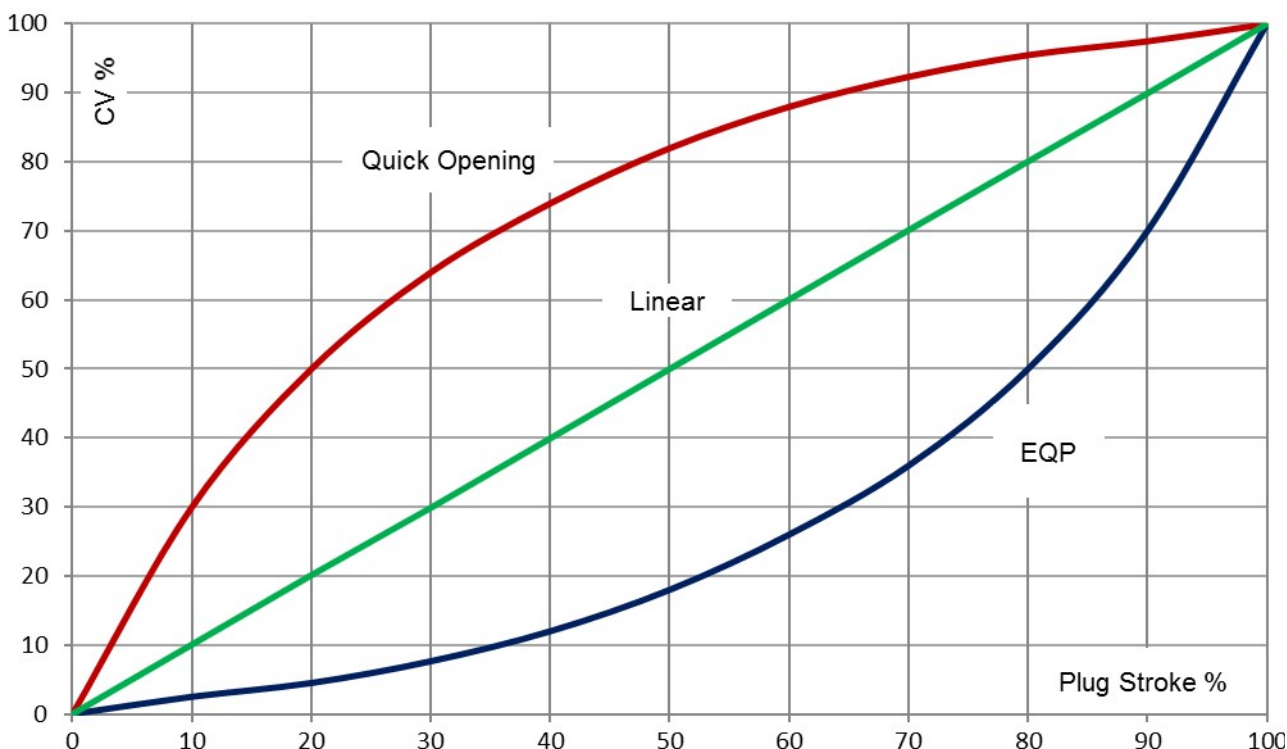
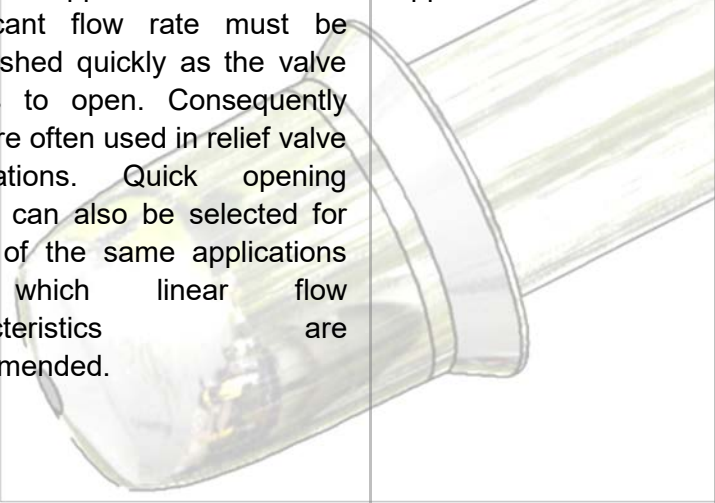



## TRIMS CHARACTERISTICS

	STANDARD	ON REQUEST
CONTROL CHARACTERISTICS	Equal Percentage (EQP)	Quick opening (ON-OFF)
		Linear (PL)
PORT	Full port	Reduced port
		Microflow port
SEAL	Metal seat tightness Class IV	Stellite faced seat/plug Class IV
		Saline nitriding (QPQ) seat/plug Class IV
		Stellite faced seat/plug Class V - Lapped Only with quick-change seat
		Lapped seat/plug Class V Only with quick-change seat
		PTFE soft seal <300°F (150°C) - Class VI
		PTFE-GR soft seal <375°F (190°C) - Class VI
		PEEK Soft seal <536°F (280°C) - Class VI

LINEAR SPLINE PLUG	QUICK OPENING PLUG	EQP PLUG METAL TIGHTNESS	EQP PLUG SOFT TIGHTNESS
			

### BALANCED PLUG CONSTRUCTION

In applications where there is a high flow rate and a high pressure drop valve actuators can struggle to provide tight shut off against the force of the upstream pressure on the plug. In these applications the balanced plug option redirects some of the upstream pressure to balance the influence of the pressure drop across the plug. This results in a more efficient actuator thrust for a particular size of actuator. This ensures the tightness class of the valve.

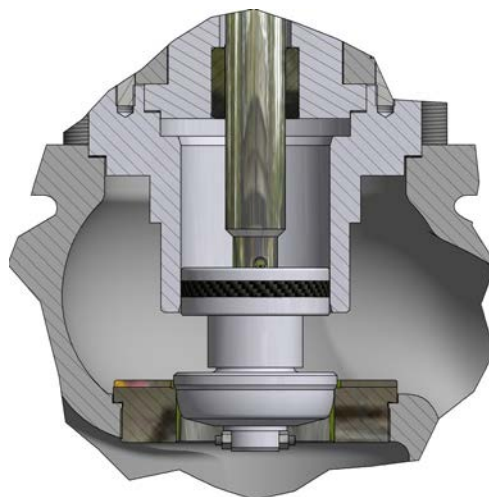

Balanced trim

## CAVITATION, FLASHING EFFECT NOISE LEVEL

The globe valve allows the regulation of a parameter which can be the pressure or flow going to modify the flow of pressurized fluid in the system. The principle used is that of the Bernoulli law or the continuity of the fluids. In a globe valve, if I decrease the passage section, the speed increases while the pressure decreases. If this pressure falls below the vapor pressure of the bubbles could be created that could produce two flow disturbance phenomena:

### **Cavitation effect** **Flashing effect**

**Cavitation** consists of rapid vaporization and condensation within a liquid. When local pressure falls to vapor pressure (approximately 0.25 psi / 0.018 bar absolute for cold water), vapor bubbles are formed and when these bubbles travel to an area of higher pressure, the bubbles collapse with phenomenal force and great localized stress. It is the violent collapse of these vapor bubbles near valve components or downstream piping surfaces, which cause cavitation damage and subsequent performance degradation. Typically, the reason for low pressure is that the pressure drop across a control valve has created very high velocity in the seat area and corresponding low pressure because potential (pressure) energy is reduced to compensate for the increase in kinetic energy. The principle can be applied to various types of fluid flow and simply states that when there is an increase in the velocity of fluids then it must be accompanied by a decrease in the fluid's pressure, the total energy associated with the flow must remain constant.

The **Flashing** effect is similar to cavitation, except that bubbles explode downstream of the valve.

In control valves, the pressure drop typically occurs at or near the seat area or just downstream. The shock waves and pressure fluctuations resulting from these high velocity bubble collapses can also cause noise, vibrations, accelerated corrosion, as well as limited valve flow. Typically the cavitation is formed in the valve throttling area, the pressure fluctuations radiate into the downstream pipe as noise

**The KA10 Series can be equipped with anticavitation and or low noise trims to reduce the possibility of cavitation and noise.**



Anticavitation Cage



Low dB Trim single stage

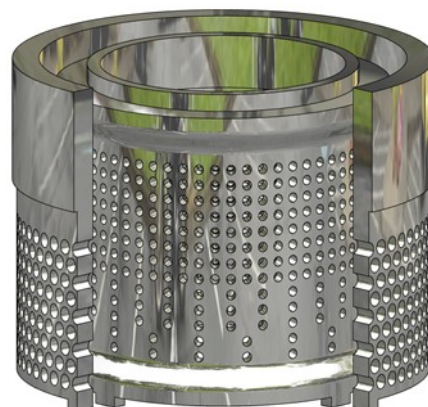

Low dB Trim double stage

## EQUAL PERCENTAGE PLUG FLOW RATE COEFFICIENTS

CV	Kv	Seat bore diameter	Std. Plug stroke	Valve size												
				15	20	25	32	40	50	65	80	100	125	150	200	
0.08	0.07	3	20	□	□	□	□	□	□	—	—	—	—	—	—	
0.20	0,17	4		□	□	□	□	□	□	—	—	—	—	—	—	
0.60	0,51	5		□	□	□	□	□	□	—	—	—	—	—	—	
1.00	0,85	7		□	□	□	□	□	□	—	—	—	—	—	—	
1.3	1,11	8		□	□	□	□	□	□	—	—	—	—	—	—	
1.8	1,54	9		□	□	□	□	□	□	—	—	—	—	—	—	
2	1,7	10		□	□	□	□	□	□	—	—	—	—	—	—	
2.5	2.15	10		□	□	□	□	□	□	—	—	—	—	—	—	
3	2,58	10		□	□	□	□	□	□	—	—	—	—	—	—	
3.5	3	10		□	□	□	□	□	□	□	□	—	—	—	—	
5.5	4.7	20		■	□	□	□	□	□	□	□	□	—	—	—	
8	6,8	20		—	■	□	□	□	□	□	□	□	—	—	—	
13	11	25		—	—	■	□	□	□	□	□	□	—	—	—	
19	16	30		—	—	—	■	□	□	□	□	□	□	□	—	
29	25	38		—	—	—	—	■	□	□	□	□	□	□	□	
50	43	49		—	—	—	—	—	■	□	□	□	□	□	□	
75	64	64		30	—	—	—	—	—	—	■	□	□	□	□	□
112	96	76			—	—	—	—	—	—	—	■	□	□	□	□
173	148	100	—	—	—	—	—	—	—	—	■	□	□	□		
190	162	100	35	—	—	—	—	—	—	—	—	□	□	□	□	
270	231	126	50	—	—	—	—	—	—	—	—	—	■	□	□	
410	351	151		—	—	—	—	—	—	—	—	—	—	■	□	
720	615	201	60	—	—	—	—	—	—	—	—	—	—	—	■	

— not available      ■ standard      □ on request

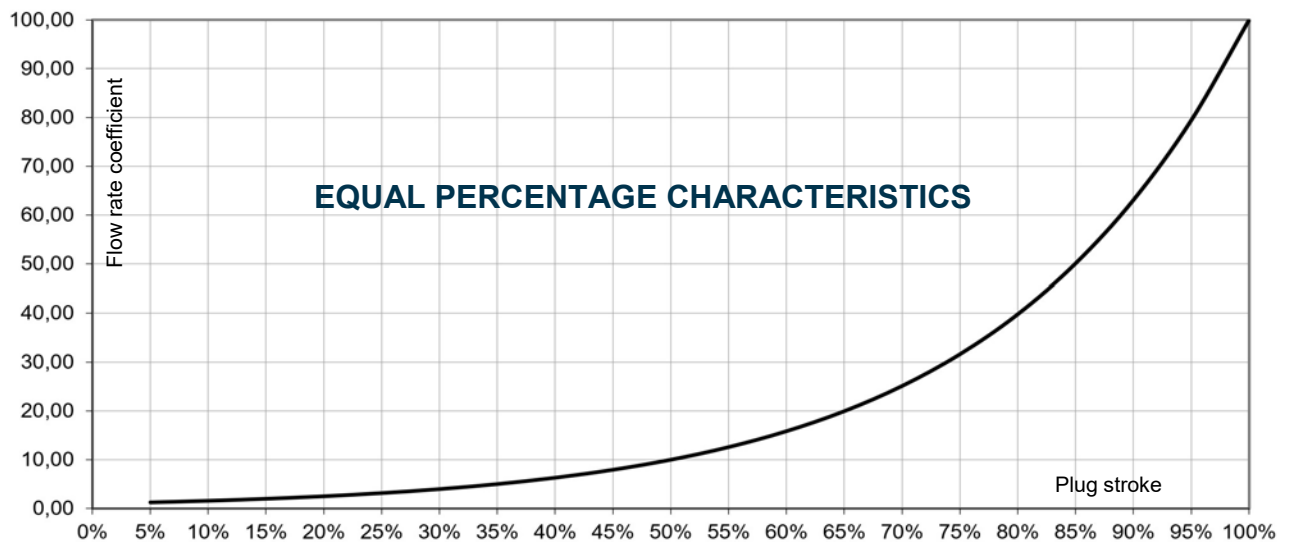

## LINEAR AND QUICK OPENING PLUG FLOW RATE COEFFICIENTS SEAT BORE DIAMETER AND STROKE

CV	Kv	Seat bore diameter mm	Std plug stroke mm	Valve size												
				15	20	25	32	40	50	65	80	100	125	150	200	
0.03	0,02	3	20	□	□	□	□	□	□	—	—	—	—	—	—	
0.05	0,04	3		□	□	□	□	□	□	□	—	—	—	—	—	—
0.08	0,07	3		□	□	□	□	□	□	□	—	—	—	—	—	—
0.20	0,17	4		□	□	□	□	□	□	□	—	—	—	—	—	—
0.60	0,51	5		□	□	□	□	□	□	□	—	—	—	—	—	—
0.75	0,65	6		□	□	□	□	□	□	□	—	—	—	—	—	—
1.00	0,85	7		□	□	□	□	□	□	□	—	—	—	—	—	—
1.3	1,11	8		□	□	□	□	□	□	□	—	—	—	—	—	—
1.8	1,54	9		□	□	□	□	□	□	□	—	—	—	—	—	—
2	1,7	10		□	□	□	□	□	□	□	—	—	—	—	—	—
2.5	2.15	10		□	□	□	□	□	□	□	—	—	—	—	—	—
3	2,58	10		□	□	□	□	□	□	□	—	—	—	—	—	—
3.5	3	10		□	□	□	□	□	□	□	□	—	—	—	—	—
6	5,1	20		■	□	□	□	□	□	□	□	□	—	—	—	—
8	6,8	20		—	■	□	□	□	□	□	□	□	—	—	—	—
13	11	25		—	—	■	□	□	□	□	□	□	—	—	—	—
19	16	30		—	—	—	■	□	□	□	□	□	□	□	—	—
29	25	38		—	—	—	—	■	□	□	□	□	□	□	□	□
50	43	49	—	—	—	—	—	■	□	□	□	□	□	□	□	
75	64	64	30	—	—	—	—	—	—	■	□	□	□	□	□	
112	96	76		—	—	—	—	—	—	—	■	□	□	□	□	
173 <sup>a</sup>	148	100		—	—	—	—	—	—	—	—	■	□	□	□	
190	162	100	35 <sup>b</sup>	—	—	—	—	—	—	—	—	□	□	□	□	
280	239	126	50	—	—	—	—	—	—	—	—	—	■	□	□	
435	372	151		—	—	—	—	—	—	—	—	—	—	—	■	□
720	615	201	60	—	—	—	—	—	—	—	—	—	—	—	■	

— not available      ■ standard      □ on request

a) not available for quick opening characteristic

b) 30mm for quick opening characteristic

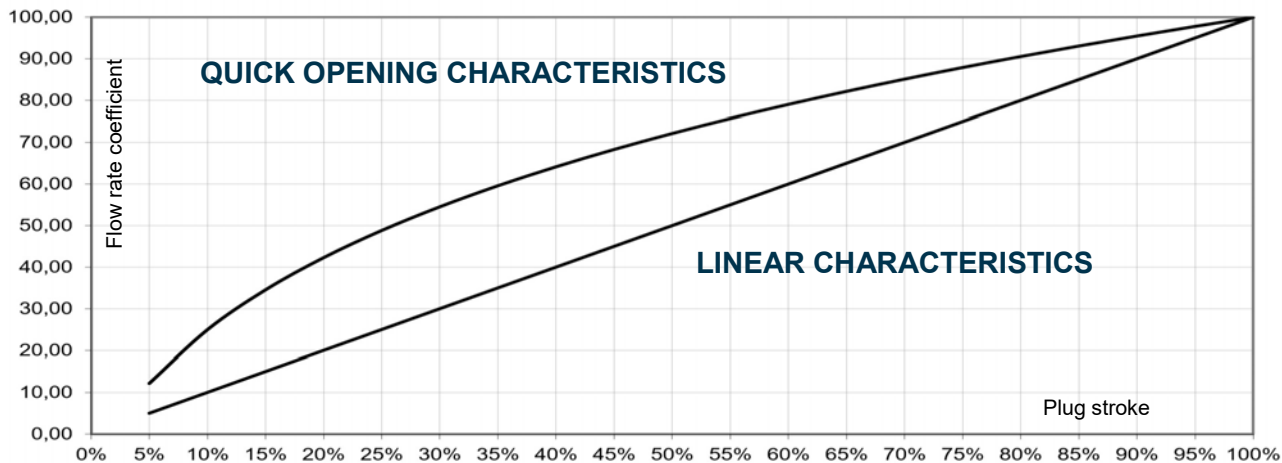



## AP SERIES PNEUMATIC ACTUATORS - SPECIFICATIONS

AP series pneumatic actuators are multi diaphragm actuators. They are Available with four (4) different sizes of internal diaphragms. They are extremely compact and they can guarantee a perfect linearity to satisfy the control needs of the valves at different working pressures. They are equipped with an industry standard yoke (CEI EN 60534-6-1), which ensures accessories can be fitted quickly and easily. A full range E/P positioners, solenoid valves, limit switch boxes and feedback devices are available as option. As you standard a mechanical travel indicator and index scale are included as standard on all actuators.

### TECHNICAL DATA

TYPE	Diaphragm type - multispring
CONTROL SIGNAL	Direct Action (Air to close - valve normally open) 3÷15psi ; 6÷18psi; 6÷30psi; 15÷60psi  Reverse (Air to open - valve normally closed) 3÷15psi ; 6÷18psi; 6÷30psi; 15÷60psi
MAX AIR SUPPLY PRESSURE	50 psi (3,5bar) for signals 3÷15psi ; 6÷18psi; 6÷30psi; 87 psi (6 bar) for signal 15÷60 psi
PNEUMATIC CONNECTION	1/4" NPF-F
AMBIENT TEMPERATURE	-4÷160°F (-20+70°C)

### MATERIALS

	STANDARD	ON REQUEST
YOKE AND CASING	Painted Carbon steel	Electropolished Stainless Steel
BOLTS AND NUTS	A193 B7 - A194 2H	Other materials
DIAPHRAGM	Nitrile butadiene rubber (NBR)	Other materials
SPLINDE	ASTM 182 F304	//
VALVE CLAMP CONNECTION	ASTM A 351 CF8	//
SPRING	EN 10270-1SH painted	Stainless steel
INTERNAL PARTS	Zinc plated carbon steel	Stainless steel

### PROTECTIVE COATING

STANDARD	Finish powder coat polyester RAL 7032
ON REQUEST	Painting for see environment Customer specification



### ACCESSORIES

- ◆ Top mounted handwheel
- ◆ Pneumatic, Electropneumatic & Smart positioners
- ◆ I/P Converter
- ◆ 4÷20 mA position feedback
- ◆ Alarm contacts
- ◆ Air filter regulator
- ◆ Solenoid valves
- ◆ Lock-Up pneumatic device

1. Casing
2. Spring
3. Diaphragm
4. Splinde
5. Integral yoke
6. Valve clamp connection
7. Stroke indicator
8. Diaphragm plate

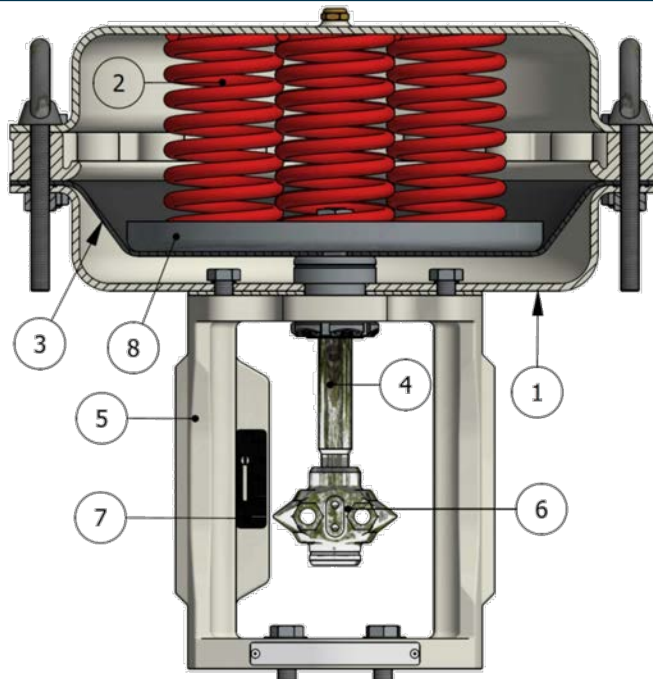

cl. IV : metal seat tightness class IV - ANSI FCI 70.2 - IEC 60534-4  
 cl. VI : soft seal class VI - ANSI FCI 70.2 - IEC 60534-4  
 the pressure drop values must be used with in the body rating limit

**MAXIMUM ADMISSIBLE PRESSURE DROPS IN bar (FLUID OPEN)  
 FOR UNBALANCED CONSTRUCTION**

ACTUATOR	THRUST kN	Signal (psi)	CV 5.5 CV 6.0		CV 8		CV 13		CV 19		CV 29		CV 50		CV 75		CV 112		CV 173		CV 190		CV 270 CV 280		CV 410 CV 435		CV 720		
			cl IV	cl VI	cl IV	cl VI	cl IV	cl VI	cl IV	cl VI	cl IV	cl VI	cl IV	cl VI	cl IV	cl VI	cl IV	cl VI	cl IV	cl VI	cl IV	cl VI	cl IV	cl VI	cl IV	cl VI	cl IV	cl VI	cl IV
AP23	0.3	3+15	14	18	14	18	9	12	5	8	3	4	2	3															
	0.4	6+18	16	22	16	22	11	17	7	10	4	5	3	4															
	0.6	6+30	22	28	22	28	16	25	10	15	6	8	4	6															
	1.5	15+60	45	60	45	60	35	56	27	33	15	17	8	12															
AP28	0.6	3+15	27	30	27	30	17	26	8	15	6	9	4	6															
	1.0	6+18	38	40	38	40	21	30	13	19	10	12	5	8															
	1.2	6+30	50	55	50	55	26	47	23	26	12	16	7	12															
AP34 / AP35	2.4	15+60	80	90	80	90	48	75	40	56	25	38	17	23															
	1.2	3+15	60	65	60	65	50	55	20	23	12	18	10	16	4	4	2	3	1	1									
	1.5	6+18	80	85	80	85	60	65	30	35	15	18	12	15	6	7	4	5	2	3									
	1.9	6+30	99	99	99	99	80	85	40	45	20	25	14	16	7	8	5	6	3	3									
AP43 / AP44	3.5	15+60							62	65	36	45	25	29	11	13	8	11	6	6									
	2.8	3+15									35	40	24	26	7	8	6	6	4	4									
	3.3	6+18									40	45	26	28	9	10	8	8	5	5									
	3.8	6+30									40	45	26	28	12	12	10	10	6	6									
AP47	7.6	15+60									65	85	40	70	28	37	22	27	15	17									
	7.6	15+60									65	85	40	70	28	37	22	27	15	17									
AP45	7.6	15+60									65	85	40	70	28	37	22	27	15	17									
AP46	7.6	15+60																			15	17	7	8	5	6	3	4	
AP60	15.5	15+60															44	54	30	34	30	34	14	16	10	12			
AP62	15.5	15+60																									6	8	

## DIMENSIONS

DN	A mm	B mm	C mm - Standard trim			C mm - Balanced trim			G mm
			Std. bonnet	Bonnet with bellows	Finned / Extended bonnet	Std. bonnet	Bonnet with bellows	Finned / Extended bonnet	
DN15	130	47.5	126	226	163	—	—	—	100
DN20	150	52.5	126	226	163	—	—	—	100
DN25	160	57.5	129	228	173	—	—	—	100
DN32	180	70	129	228	173	—	—	—	100
DN40	200	75	128	226	185	—	—	—	100
DN50	230	82.5	128	226	185	157	256	214	100
DN65 (*)	290	92.5	165	292	255	218	334	277	100
DN80	310	100	187	306	260	230	348	282	100
DN100	350	110	184	307	310	245	365	310	100
DN125	400	125	256	369	369	352	472	394	120
DN150	480	142.5	259	372	372	356	476	398	120
DN200	600	170	283	395	395	380	500	422	120

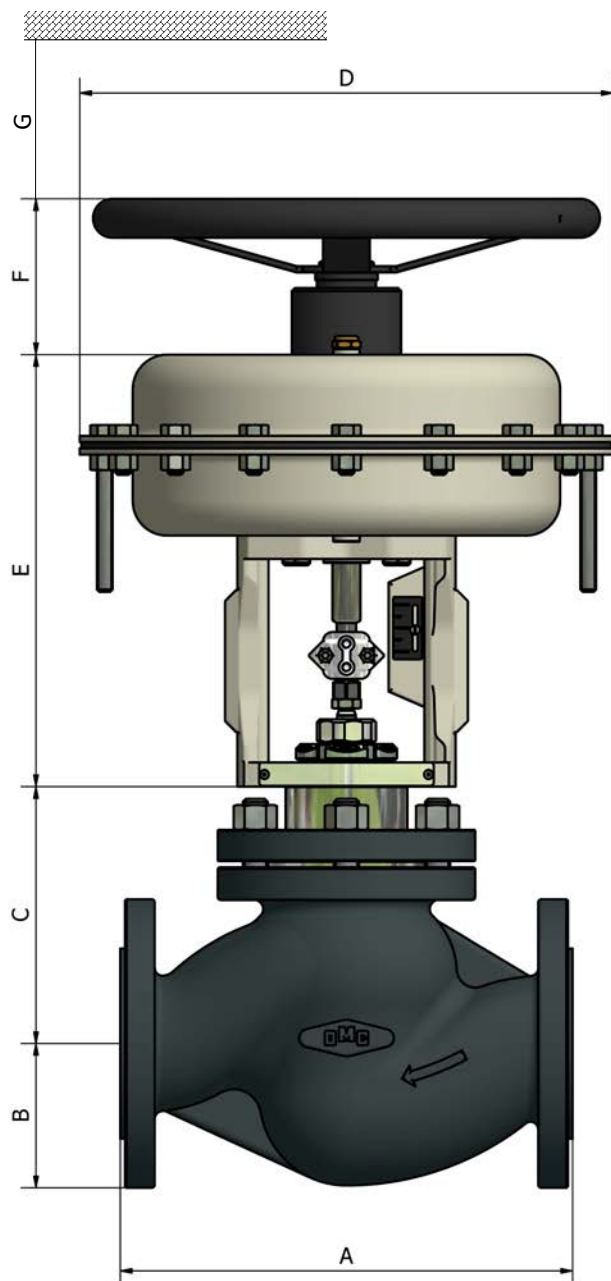

(\*) According to standard EN1092-1 DN65 valves in carbon steel and stainless steel flanged PN16 must be provided with 8 holes. They can be supplied with 4 holes only at the specific request of the customer.

### ACTUATOR

TYPE	Ø D mm	E mm	F mm		THRUST AREA (cm <sup>2</sup> )	THRUST VOLUME liter
			N.A. (DIR.)	N.C. (INV.)		
AP23	230	245	135	85	203	~ 1.8
AP28	275	253			304	~ 3
AP34 AP35	342	276	185	85	475	~ 5.7
AP43 AP44	430	303	300	150	744	~ 13.5
AP45		393				
AP47		335	300	150		
AP46		425	300	150		
AP60	600	450	//	//	1690	~ 32
AP62	600	480	//	//	1690	~ 40

## PNEUMATIC PISTON SERIES OP

The OP series pneumatic actuators are used especially for multi-spring piston valves with ON-OFF function. Available in 2 sizes, are extremely compact. Equipped with mechanical stroke indicator, the integral yoke meets Std CEI EN60534-6-1 to direct mounting accessories such as, switches, etc ...

### TECHNICAL DATA

TYPE	Piston type - multispring
CONTROL SIGNAL	from 90 psi (6 bar) to 145 psi (10 bar)
MAX AIR SUPPLY PRESSURE	145 psi (10 bar)
PNEUMATIC CONNECTION	1/4" NPF-F
AMBIENT TEMPERATURE	-4÷160°F (-20+70°C)

### MATERIALS

	STANDARD	ON REQUEST
CASING	Painted Aluminium	Electropolished Stainless Steel
YOKE	Painted Carbon steel	Electropolished Stainless Steel
BOLTS AND NUTS	A193 B7 - A194 2H	Other materials
PISTON	NBR	//
SPLINDE	ASTM 182 F304	//
VALVE CLAMP CONNECTION	ASTM A 351 CF8	//
SPRING	EN 10270-1SH painted	Stainless steel
INTERNAL PARTS	Zinc plated carbon steel	Stainless steel

### PROTECTIVE COATING

STANDARD	Finish powder coat polyester RAL 7032
ON REQUEST	Painting for see environment Customer specification

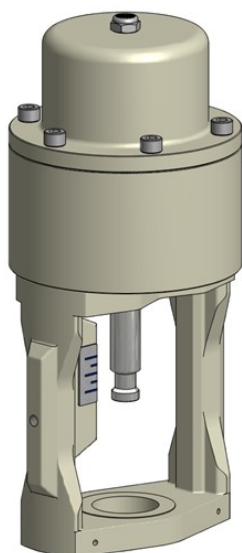

### ACCESSORIES

- ◆ Alarm contacts
- ◆ Air filter regulator
- ◆ Solenoid valves
- ◆ Lock-Up pneumatic device

### MAXIMUM ADMISSIBLE PRESSURE DROPS IN bar (FLUID OPEN) FOR UNBALANCED CONSTRUCTION

ACTUATOR	CV 6	CV 8	CV 13	CV 19	CV 29	CV 50	CV 75	CV 112	CV 173 CV190
OP10	12	12	12	12	12	12			
OP16							12	8	3



## DIMENSIONS

DN	A mm	B mm	C mm - Standard trim			C mm - Balanced trim			G mm
			Std. bonnet	Bonnet with bellows	Finned / Extended bonnet	Std. bonnet	Bonnet with bellows	Finned / Extended bonnet	
DN15	130	47.5	126	226	163	—	—	—	100
DN20	150	52.5	126	226	163	—	—	—	100
DN25	160	57.5	129	228	173	—	—	—	100
DN32	180	70	129	228	173	—	—	—	100
DN40	200	75	128	226	185	—	—	—	100
DN50	230	82.5	128	226	185	157	256	214	100
DN65 (*)	290	92.5	165	292	255	218	334	277	100
DN80	310	100	187	306	260	230	348	282	100
DN100	350	110	184	307	310	245	365	310	100

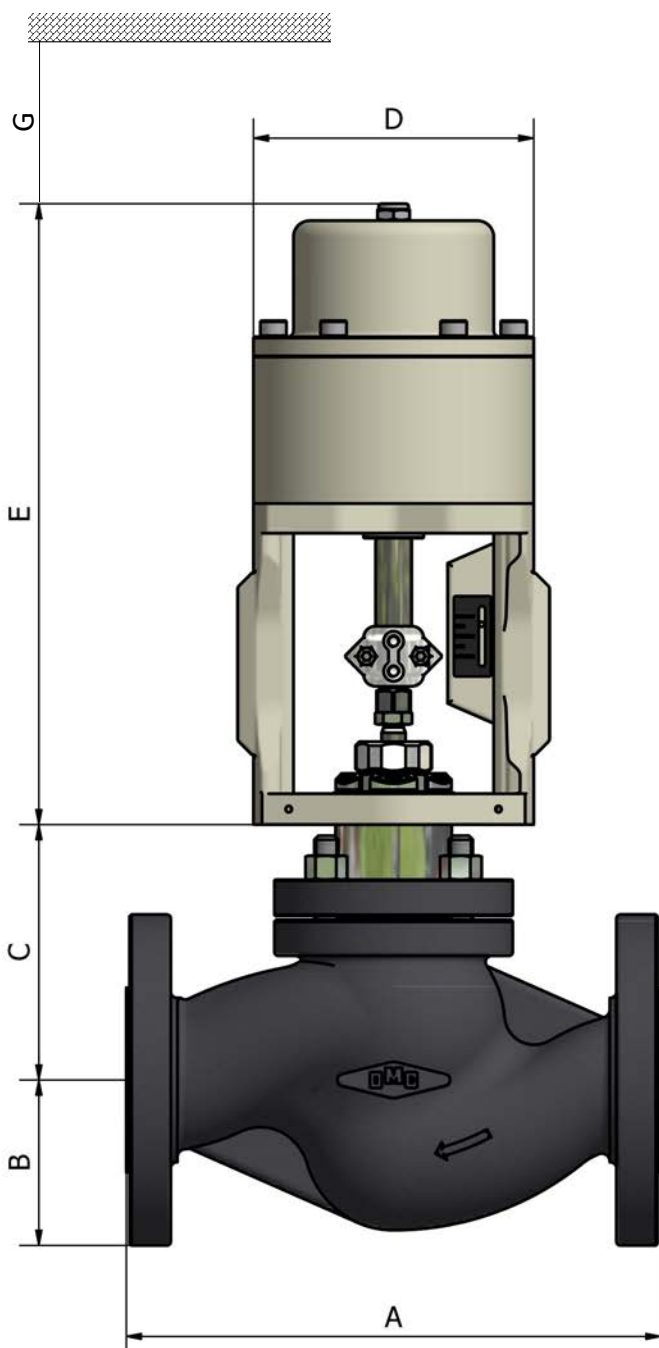

(\*) According to standard EN1092-1 DN65 valves in carbon steel and stainless steel flanged PN16 must be provided with 8 holes. They can be supplied with 4 holes only at the specific request of the customer.

### ACTUATOR

TYPE	Ø D inches (mm)	E inches (mm)		
		½ - 1" ½	2"	3" - 4"
OP10	9.05 (230)	10.51 (267)	11.50 (292)	//
OP16	10.82 (275)	//	//	13.19 (335)

## ELECTRIC ACTUATORS

The OMC control valves can be supplied with electric actuators of the best manufacturers to meet the most varied demands in the industrial processes.



## AVAILABLE ENDS CONNECTIONS



RAISED FACE



RING JOINT FACE



MALE FACE



FEMALE FACE



FLAT FACE



BUTT-WELDING



SOCKET-WELDING



GROOVE FACE

## VALVE BODY WEIGHT (Kg)

SIZE	Standard		Finned / Extended		With bellows	
	PN16	PN40	PN16	PN40	PN16	PN40
DN15	4.8	4.9	5.3	5.4	6.1	6.2
DN20	5.8	5.9	6.3	6.4	7	7.2
DN25	7	7.1	7.7	7.8	8.1	8.2
DN32	8.7	8.9	9.4	6.5	9.8	10
DN40	12.2	12.4	13.3	13.6	13.9	14.1
DN50	16	16.3	17.2	17.5	17.7	18
DN65	28.2	28.6	31.3	31.8	32.4	32.9
DN80	34.4	34.8	37.5	38	38.5	39.1
DN100	46.7	47.4	51.4	52	50.6	51.4
DN125	99.3	100.8	107.1	108.8	106	107.6
DN150	132.7	134.8	140.6	142.8	139.4	141.6
DN200	199.2	202.4	207.2	210.5	205.89	209.2

## PNEUMATIC ACTUATOR WEIGHT (Kg)

TYPE	SIGNAL	ACTUATOR	HAND WHEEL
AP23	3÷15 / 6÷18 / 6÷30	7	1
	15÷60	8	
AP28	3÷15 / 6÷18 / 6÷30	9	
	15÷60	10	
AP34 / AP35	3÷15 / 6÷18 / 6÷30	15	2
	15÷60	17	
AP43 / AP44	3÷15 / 6÷18 / 6÷30	27	3
	15÷60	32	7
AP45	15÷60	38	7
AP46	15÷60	45	7
AP47	15÷60	45	7
AP60	15÷60	155	//
AP62	15÷60	169	//
OP10	ON-OFF	8	//
OP16	ON-OFF	13	//

*The contents of this publication are presented for information purpose only. We reserve to modify or improve the designs or specifications of such products at any time without notice*



**OMC s.r.l.**

Via Galileo Galilei, 18 - 20060  
Cassina de Pecchi (MI) - ITALY

Tel.: (+39) 02.95.28.468  
Fax: (+39) 02.95.21.495