



# VL10 **PN16**

*Pneumatic & Electric Globe Control Valve European std.*

The **VL10** is a single seated, two-port control valve, with in-line straight PN16 Flanged connections.

The **VL10** valves have been designed to provide accurate control in any process condition.

It is particularly suitable for a wide range of control applications, where fluids such as water, superheated water, steam, air, gas require accurate control.



14/68/EU Directive (PED)  
14/34/EU (ATEX)



Safety Integrity Level  
IEC EN 61508 - TÜV



- ◆ From DN15 to DN100 PN16
- ◆ Modular design
- ◆ CEI EN 60534-6-1 Clamp and Yoke Std.
- ◆ Std. self adjusting double packing spring loaded
- ◆ Shutoff capabilities : Class VI

1. Body Valve
2. Seat Ring
3. Plug
4. Stem guide
5. Valve Bonnet
6. Stuffing box

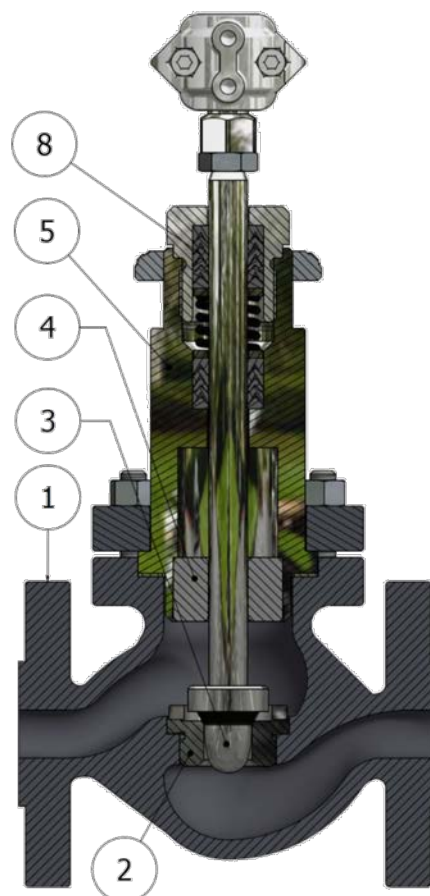

### STD VALVE BODY CHARACTERISTICS

Style	Top entry, single seated, globe valve
Sizes	From DN15 to DN100
Pressure rating	PN16
Design std.	EN12516-2
Flange connection	EN 1092-2- Raised Face Phonography serrated 125-250 AARH
Face to face dimensions	EN 558-1

### STD BODY & TRIM MATERIALS COMBINATION

VALVE BODY	BONNET	TRIM	TIES ROAD	NUTS
Spheroidal graphite cast iron: EN-GJS-400-18 RT (5.3104)	ASTM A105 EN 10273 1.0345	ASTM A182 F316 EN 10272 1.4529	A193 B7	A194 H2

### WORKING PRESSURE BY CLASS STD MATERIALS (EN1092.2)

OPERATING TEMPERATURE	EN-GJS-400-18 RT (5.3104) (-10° + 350°C)	ASTM A105 / EN10273 1.0619 / EN10273 1.0345 (-29° + 450°C)
°C	PN16 (bar)	PN16 (bar)
-10 + 120	16.0	16.0
150	15.5	14.0
200	14.7	13.3
250	13.9	12.1
300	12.8	11.0
350	11.2	10.2

### STANDARD PROTECTIVE COATING

WORKING TEMPERATURE	VALVE BODY	BONNET
from -10° to 150°C	<ul style="list-style-type: none"> <li>• Bicomponent anticorrosive acrylic primer at high resistance</li> <li>• Finish with bicomponent aliphatic acrylic enamel RAL 7021 opaque</li> </ul>	Electrolytic zinc coatings Fe/Zn 8 c1A UNI ISO 4520



## BONNET

The bonnet is forged in ASTM A105 Cast Steel. It is suitable for applications with temperatures between  $-5$  to  $+200^{\circ}\text{C}$ .

## SP200 PACKING

Self-adjusting and low emission Double V-ring pack spring loaded. Suitable for temperature service up to  $200^{\circ}\text{C}$ .

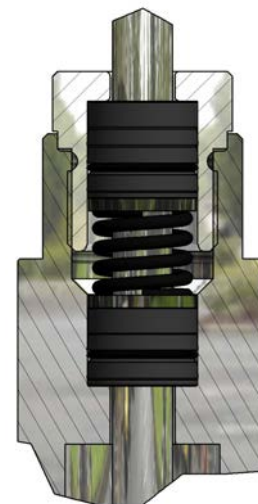

## TRIMS CHARACTERISTICS

	STANDARD
CONTROL CHARACTERISTICS	Equal Percentage (EQP)
PORT	Full port
SEAL	PTFE-GR soft seal $190^{\circ}\text{C}$ - Class VI

## FLOW RATE COEFFICIENTS SEAT BORE DIAMETER AND PLUG STROKE

CV	Kv	Seat bore diameter mm	Std plug stroke mm	Valve size (DN)										
				15	20	25	32	40	50	65	80	100		
4.5	3.8	15	20	■	—	—	—	—	—	—	—	—	—	
6	5.1	20		—	■	—	—	—	—	—	—	—	—	
11	9.4	25		—	—	■	—	—	—	—	—	—	—	
18	15.4	30		—	—	—	■	—	—	—	—	—	—	
27	22.2	38		—	—	—	—	■	—	—	—	—	—	
47	40.1	49		—	—	—	—	—	—	■	—	—	—	
73	63.4	64	30	—	—	—	—	—	—	■	—	—		
105	89.7	76		—	—	—	—	—	—	—	—	■	—	
160	136.7	96		—	—	—	—	—	—	—	—	—	—	■
				—	—	—	—	—	—	—	—	—	—	—

— not available

■ standard

## AL SERIES PNEUMATIC ACTUATORS - SPECIFICATIONS

AP series pneumatic actuators are multi diaphragm actuators. They are Available with four (4) different sizes of internal diaphragms. They are extremely compact and they can guarantee a perfect linearity to satisfy the control needs of the valves at different working pressures. They are equipped with an pillar yoke (CEI EN 60534-6-1). A full range E/P positioners, solenoid valves, limit switch boxes and feedback devices are available as option. As you standard a mechanical travel indicator and index scale are included as standard on all actuators.

### TECHNICAL DATA

TYPE	Diaphragm type - multispring
CONTROL SIGNAL	Direct Action (Air to close - valve normally open) 3÷15psi ; 6÷18psi; 6÷30psi; 15÷60psi Reverse (Air to open - valve normally closed)
MAX AIR SUPPLY PRESSURE	50 psi (3,5bar) for signals 3÷15psi ; 6÷18psi; 6÷30psi; 87 psi (6 bar) for signal 15÷60 psi
PNEUMATIC CONNECTION	1/4" NPF-F
AMBIENT TEMPERATURE	-20+70°C

### MATERIALS

YOKE AND CASING	Painted Carbon steel
BOLTS AND NUTS	A193 B7 - A194 2H
DIAPHRAGM	Nitrile butadiene rubber (NBR)
SPLINDE	ASTM 182 F304
VALVE CLAMP CONNECTION	ASTM A 351 CF8
SPRING	EN 10270-1SH painted
INTERNAL PARTS	Zinc plated carbon steel

### PROTECTIVE COATING

STANDARD	Finish powder coat polyester RAL 7032
----------	---------------------------------------



### ACCESSORIES

- ◆ Top mounted handwheel
- ◆ Pneumatic, Electropneumatic & Smart positioners
- ◆ I/P Converter
- ◆ 4÷20 mA position feedback
- ◆ Alarm contacts
- ◆ Air filter regulator
- ◆ Solenoid valves
- ◆ Lock-Up pneumatic device

1. Casing
2. Spring
3. Diaphragm
4. Splinde
5. Pillar yoke
6. Valve clamp connection
7. Stroke indicator
8. Diaphragm plate

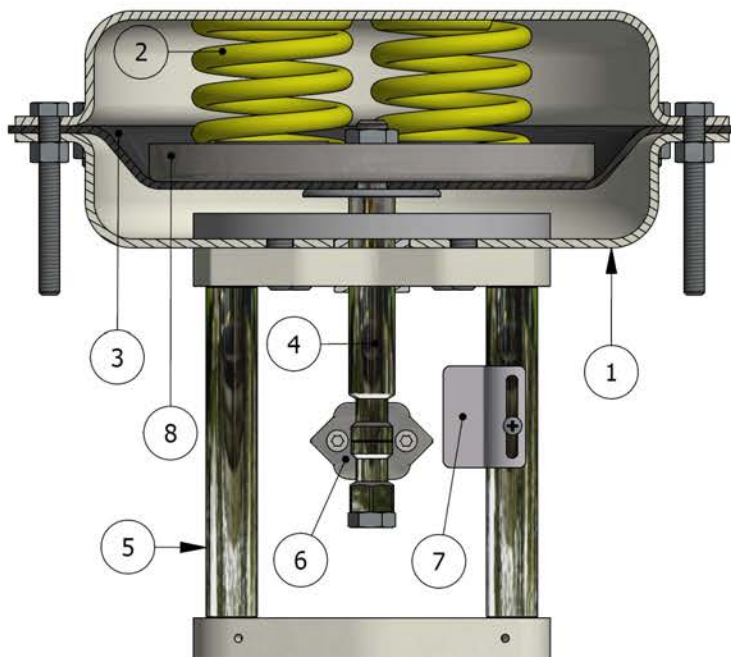

### MAXIMUM ADMISSIBLE PRESSURE DROPS IN bar (FLUID OPEN)

ACTUATOR	SIGNAL (psi)	CV 4,5	CV 6	CV 11	CV 18	CV 27	CV 47	CV 73	CV 105	CV 160
		cl VI	cl VI	cl VI	cl VI	cl VI	cl VI	cl VI	cl VI	cl VI
AL23	3+15	21	18	12	8	4	3			
	6+18	26	22	17	10	5	4			
	6+30	60	28	25	15	8	6			
	15+60	80	60	56	33	17	12			
AL28	3+15	35	30	26	15	9	6			
	6+18	45	40	30	19	12	8			
	6+30	60	55	47	26	16	12			
	15+60	99	90	75	56	38	23			
AL34 / AL35	3+15	65	65	55	23	18	16	4	3	1
	6+18	85	85	65	35	18	15	7	5	3
	6+30	99	99	85	45	25	16	8	6	3
	15+60				65	45	29	13	11	6
AL43 / AL44	3+15					40	26	8	6	4
	6+18					45	28	10	8	5
	6+30					45	28	12	10	6
	15+60					85	70	37	27	17

cl. VI : soft seal class VI - ANSI FCI 70.2 - IEC 60534-4  
 the pressure drop values must be used with in the body rating limit

## DIMENSIONS

SIZE	A mm	B mm	C mm
DN15	130	47.5	126
DN20	150	52.5	126
DN25	160	57.5	129
DN32	180	70	129
DN40	200	75	128
DN50	230	82.5	128
DN65 (*)	290	92.5	165
DN80	310	100	187
DN100	350	110	184

(\*) According to standard EN1092-2 DN65 valves in cast iron flanged PN16 must be provided with 4 holes. They can be supplied with 8 holes only at the specific request of the customer.

ACTUATOR					
TYPE	Ø D mm	E mm	F mm	THRUST AREA cm <sup>2</sup>	THRUST VOLUME liter
AL23	230	245	110	203	~ 1,8
AL28	275	253		304	~ 3
AL34	342	276	150	475	~ 5.7
AL35					
AL43	430	303	300	744	~ 11.5
AL44					

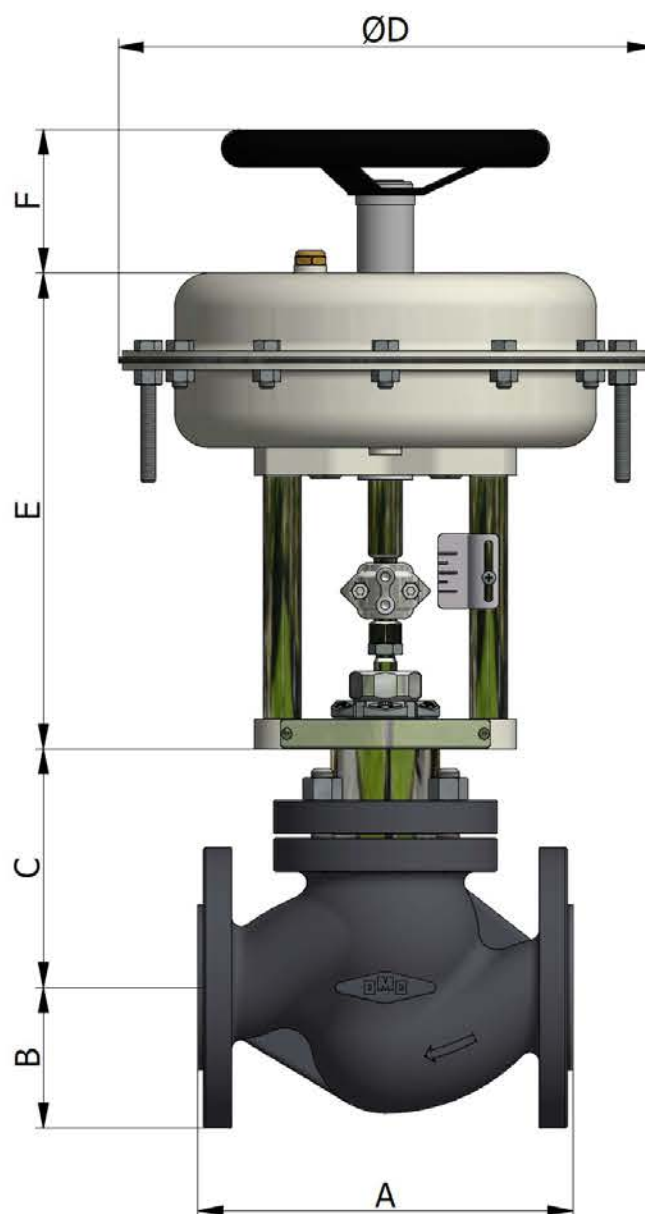

## PNEUMATIC PISTON SERIES OP

The OP series pneumatic actuators are used especially for multi-spring piston valves with ON-OFF function. Available in 2 sizes, are extremely compact. Equipped with mechanical stroke indicator, the pillar yoke meets Std CEI EN60534-6-1 to direct mounting accessories such as, switches, etc ...

### TECHNICAL DATA

TYPE	Piston type - multispring
CONTROL SIGNAL	from 90 psi (6 bar) to 145 psi (10 bar)
MAX AIR SUPPLY PRESSURE	145 psi (10 bar)
PNEUMATIC CONNECTION	1/4" NPF-F
AMBIENT TEMPERATURE	-4÷160°F (-20+70°C)

### MATERIALS

	STANDARD
CASING	Painted Aluminium
YOKE	Carbon steel
BOLTS AND NUTS	A193 B7 - A194 2H
PISTON	NBR
SPLINDE	ASTM 182 F304
VALVE CLAMP CONNECTION	ASTM A 351 CF8
SPRING	EN 10270-1SH painted
INTERNAL PARTS	Zinc plated carbon steel

### PROTECTIVE COATING

STANDARD	Finish powder coat polyester RAL 7032
----------	---------------------------------------

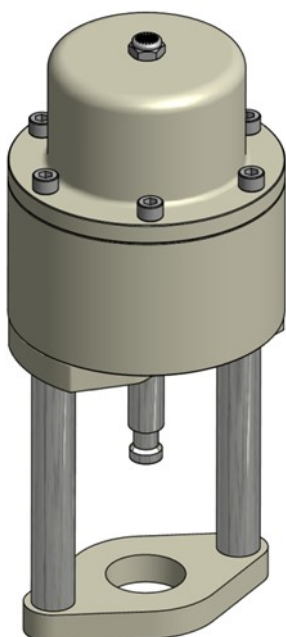

### ACCESSORIES

- ◆ Alarm contacts
- ◆ Air filter regulator
- ◆ Solenoid valves
- ◆ Lock-Up pneumatic device

### MAXIMUM ADMISSIBLE PRESSURE DROPS IN bar (FLUID OPEN) FOR UNBALANCED

ACTUA-TOR	CV 4,5	CV 6	CV 11	CV 18	CV 27	CV 47	CV 73	CV 105	CV 160
OL10	12	12	12	12	12	12			
OL16							12	8	3

## DIMENSIONS

SIZE	A mm	B mm	C mm
DN15	130	47.5	126
DN20	150	52.5	126
DN25	160	57.5	129
DN32	180	70	129
DN40	200	75	128
DN50	230	82.5	128
DN65 (*)	290	92.5	165
DN80	310	100	187
DN100	350	110	184

(\*) According to standard EN1092-2 DN65 valves in cast iron flanged PN16 must be provided with 4 holes. They can be supplied with 8 holes only at the specific request of the customer.

ACTUATOR				
TYPE	Ø D mm	E mm		
		DN15÷40	DN50	DN65÷100
OL10	230	267	292	//
OL16	275	//	//	335

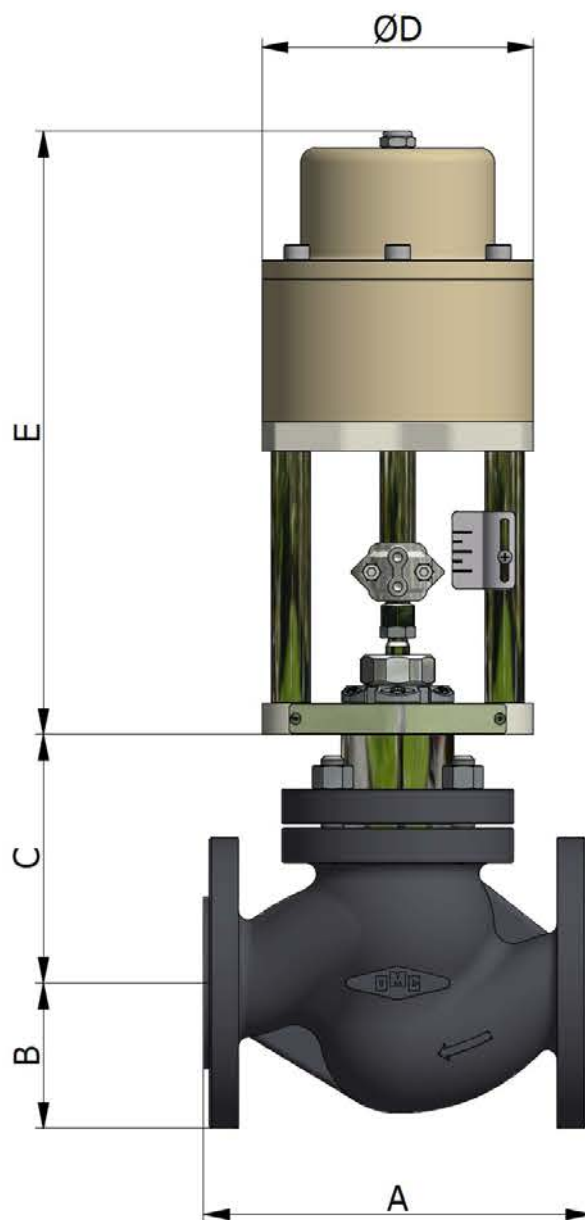



## ELECTRIC ACTUATOR

The OMC control valves can be supplied with electric actuators of the best manufacturers to meet the most varied demands in the industrial processes.



## VALVE BODY WEIGHT

SIZE	Kg
DN15	4.6
DN20	5.1
DN25	6.7
DN32	8.1
DN40	11.1
DN50	14.2
DN65	25.2
DN80	29.0
DN100	39.4

## PNEUMATIC ACTUATOR WEIGHT

TYPE	SIGNAL	ACTUATOR Kg	HAND WHEEL Kg
AP23	3÷15 / 6÷18 / 6÷30	7	1
	15÷60	8	
AP28	3÷15 / 6÷18 / 6÷30	9	
	15÷60	10	
AP34 / AP35	3÷15 / 6÷18 / 6÷30	15	2
	15÷60	17	
AP43 / AP44	3÷15 / 6÷18 / 6÷30	27	3
	15÷60	32	7
AP60	15÷60	155	//
OP10	ON-OFF	8	//
OP16	ON-OFF	13	//

*The contents of this publication are presented for information purpose only. We reserve to modify or improve the designs or specifications of such products at any time without notice*



**OMC s.r.l.**

Via Galileo Galilei, 18 - 20060  
Cassina de Pecchi (MI) - ITALY  
Tel.: (+39) 02.95.28.468  
Fax: (+39) 02.95.21.495  
info@omcsrl.com