

# INSTALLATION, OPERATION AND MAINTENANCE MANUAL

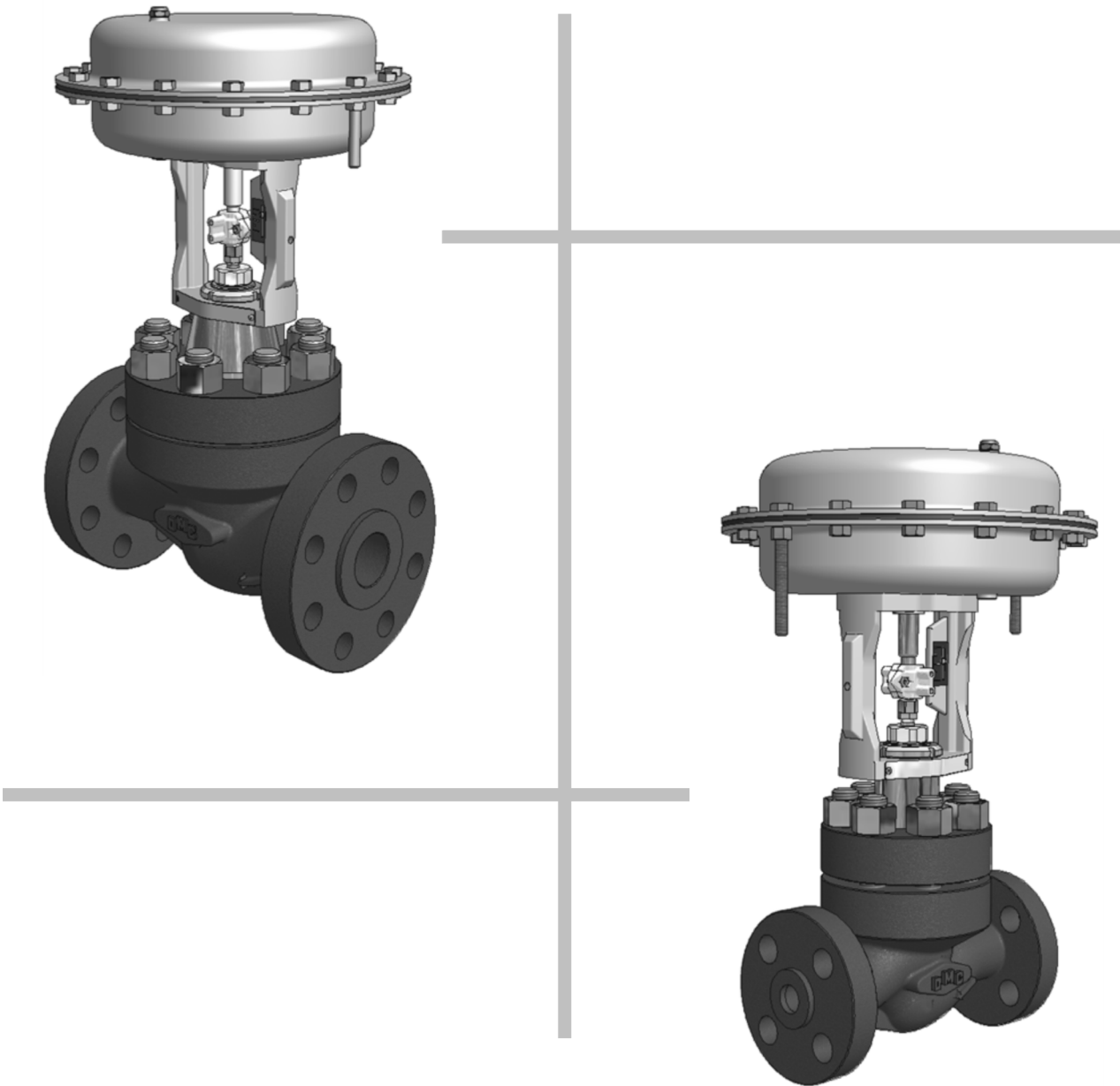

Our products are manufactured under ISO-9001 Quality Assurance System, approved by CSQ certified under no.9190.OMC2 - FIRST ISSUE 1994/08/04



## Globe valves **SERIES KA30**

# TABLE OF CONTENTS

## 1.0 SAFETY INFORMATION

- 1.01 INTENDED USE
- 1.02 ACCESS
- 1.03 LIGHTING
- 1.04 HAZARDOUS FLUIDS IN THE PIPE
- 1.05 ENVIRONMENTAL SITUATIONS
- 1.06 TEMPERATURE
- 1.07 SYSTEM
- 1.08 PRESSURIZED SYSTEMS
- 1.09 TOOLS AND CONSUMABLE PARTS
- 1.10 PROTECTION CLOTHES
- 1.11 QUALIFICATION OF OPERATORS IN CHARGE OF THE WORKS
- 1.12 HANDLING
- 1.13 FREEZING
- 1.14 OTHER RISKS
- 1.15 DISPOSAL
- 1.16 RISK OF CORROSION AND/OR EROSION

## 2.0 INSTALLATION

- 2.01 ASSEMBLY OF THE VALVE ON THE PIPE

## 3.0 ACTUATOR CONNECTION

- 3.01 PNEUMATIC ACTUATOR CONNECTION
- 3.02 ELECTRIC ACTUATOR CONNECTION

## 4.0 MAINTENANCE

- 4.01 VALVE/ACTUATOR SEPARATION
- 4.02 REPLACEMENT OF THE PLUG SEAT
- 4.06 REPLACEMENT OF THE STEM PACKING GLAND

## 5.0 TIGHTENING TORQUES

## 6.0 SIZES OF ACTUATOR CONNECTION

## 7.0 PERIODICAL OPERATIONS

## 8.0 AVAILABLE SPARE PARTS

## 9.0 PRESSURE/TEMPERATURE REPORT OMC-TUV-00 Rev.03/2018

## 1.0 SAFETY INFORMATION

The safe operation of this product is ensured only if it is installed, commissioned, used and maintained in an appropriate way by qualified personnel in compliance with the operating instructions.

### 1.01 INTENDED USE

Verify that the actuator is suitable for the intended use and application by controlling:

- that the material of which the valve is made up of is compatible with the process fluid;
- that the valve is suitable to the pressures and temperatures of the process fluid;
- to have arranged a suitable safety device which prevents, in case of valve malfunctioning, any hazardous overpressures or overtemperatures.

The OMC valves are not intended to withstand any external stresses which can be induced by the systems in which they are inserted. The installer must take account of these stresses and take the appropriate measures.

### 1.02 ACCESS

Ensure a safe access and, if required, a safe working platform (with a suitable protection) before operating on the product. Arrange the suitable lifting means, if required.

### 1.03 LIGHTING

Ensure a lighting which is suitable to the required type of work.

### 1.04 HAZARDOUS FLUIDS IN THE PIPE

Take account of the content of the pipe or anything it may have previously contained. Be careful to: flammable materials, substances hazardous for the health, temperature extremes.

### 1.05 ENVIRONMENTAL SITUATIONS

Take account of: areas at risk of explosion, lack of oxygen (such as tanks, wells, etc...), hazardous gases, temperature limits, high or low temperature surfaces, risk of fire (for example during welding operations), excessive noise, moving machines.

### 1.06 TEMPERATURE

Wait until the temperature normalizes after the interception to prevent any risks of burn or freezing.

### 1.07 SYSTEM

Take account of the possible effects on the whole expected working system.

#### **May the intended measure put the other parts of the system or the personnel at risk?**

Make sure that the shut-off valves are gradually activated in order to prevent any abrupt variations to the system.

### 1.08 PRESSURIZED SYSTEMS

Make sure that the pressure is isolated and discharged to the atmospheric pressure in safe conditions. Take account of a double insulation (double block and vent) and the blocking or the labelling of the closed valves. Do not consider the system depressurized even if the pressure gauge indicates zero pressure.

**During the operation the valve is pressurized. Before performing any maintenance operation or action on the flanges and closing caps, make sure that the line is depressurized (0 bar) and at ambient temperature.**

## 1.09 TOOLS AND CONSUMABLE PARTS

Before starting the work, make sure to have at your disposal all the tools required to perform it, do not make use of inappropriate tools. Use only OMC original spare parts.

## 1.10 PROTECTION CLOTHES

Take account of whether you and/or others need some clothes against the hazards, such as chemical products, temperatures, radiations, noise, fall of objects, risks for eyes and face.

## 1.11 QUALIFICATION OF THE OPERATORS IN CHARGE OF THE WORKS

All works must be performed and supervised by some skilled, trained and competent personnel.

## 1.12 HANDLING

Use suitable lifting means for the handling of the products by assessing all the risks concerning the lifting, the environment load, the individual and the circumstances of the work which is about to be performed.

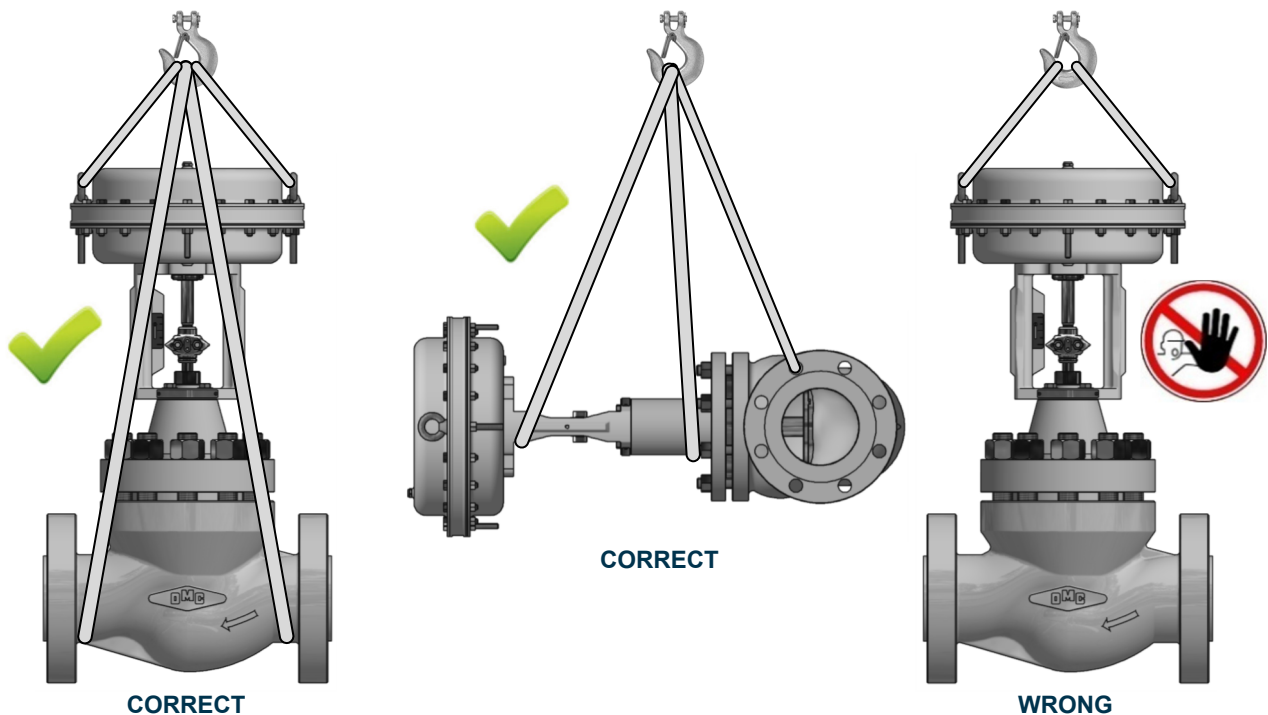

## 1.13 FREEZING

Protect the products against frozen in environments with temperatures lower than the freezing point of the process fluid.

## 1.14 OTHER RISKS

During the operation, the external surface of the product can be at temperatures which are hazardous to touch. Take account of this risk.

## 1.15 DISPOSAL

For the disposal respect the legislation in force in the State/Country/Nation where the product should be disposed of.

## 1.16 RISK OF CORROSION AND/OR EROSION

Periodically verify any phenomena of internal and/or external corrosion and/or erosion as they may significantly damage the pressurized parts by locally reducing the thickness and as a consequence the safety degree.

## 2.0 INSTALLATION

**All works must be performed and supervised by skilled, trained and competent personnel.**

The fusion of the OMC valves' body highlights the flow direction, the maximum operating pressure and the material.

Before installing the valve, make sure that the pipe which channels the process fluid is clean, by performing, if required, an energetic blowing with steam or compressed air.

The installation of a filter (pos. A Pic. 1) upstream the valve will prevent the entrance of any dirt in the plug.

To perform periodical maintenance operations of the valves installed on continuous-operation systems, it is recommended to install two shut-off valves, located upstream (pos. B Pic. 1) and downstream (pos. C Pic. 1) of the control valve, and a by-pass one (pos. D Pic. 1). Use the by-pass valve (pos. D Pic. 1) to manually regulate the process when the control valve is temporarily disconnected. The two shut-off valves must have the same internal diameter of the control valve. During the installation of the valve, make sure that the flow in the pipe goes in the same direction as indicated by the arrow on the valve body.

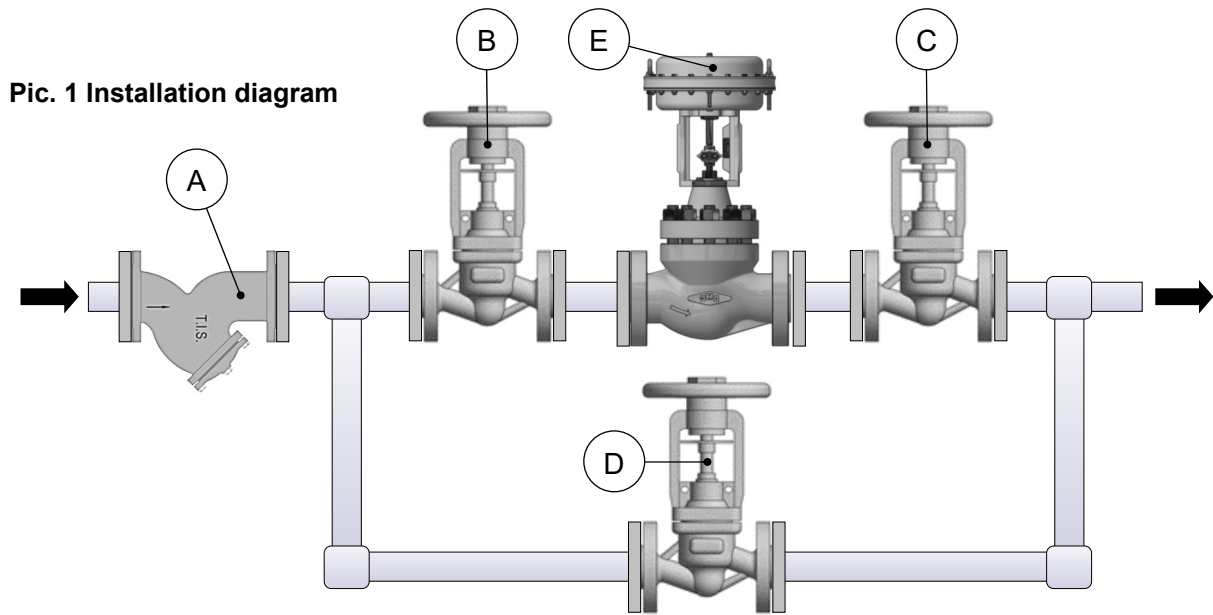

**Pic. 1 Installation diagram**

The assembling position of the valve does not limit its operation, but it is recommended to assemble the valve with the actuator pointed upward (pos. E Pic.1) as other positions might allow the accumulation of any impurities which are contained in the fluid thus damaging the valve itself.

### 2.01 ASSEMBLY OF THE VALVE ON THE PIPE

To ensure a uniform load and a uniform alignment, the flange bolts must be gradually tightened in criss-cross sequence, as indicated in Pic.2

**Prevent any excessive tightening. Use the recommended tightening torques. Prevent any pipe misalignment. Choose the flange gaskets according to the operating conditions.**

**ATTENTION!!!** For valves with braze-on connections, the welding operation must be performed only by qualified personnel and, in order to prevent any damages to the valves, keep the valve body cold during the above-mentioned operation.

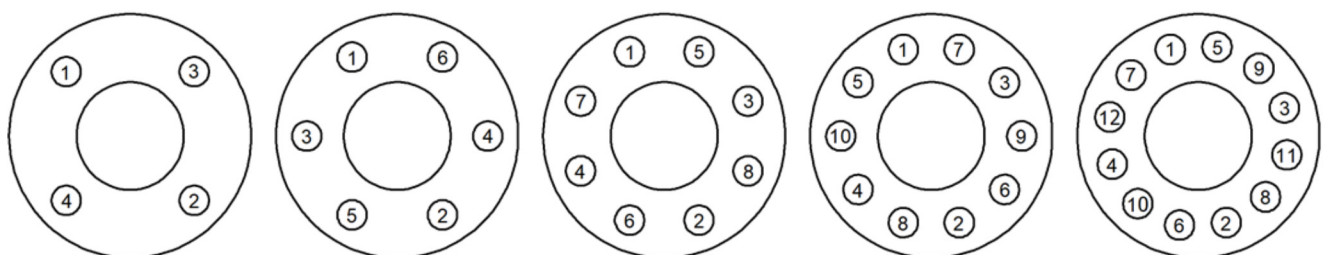

**Pic. 2 Tightening sequence**



**ATTENTION!!!** Any excessive weight of the valve might damage the system structure. If required, support the valve by using suitable devices (Pic.3) and/or ropes (Pic.4)

**Pic. 3 Installation with supports on the ground**

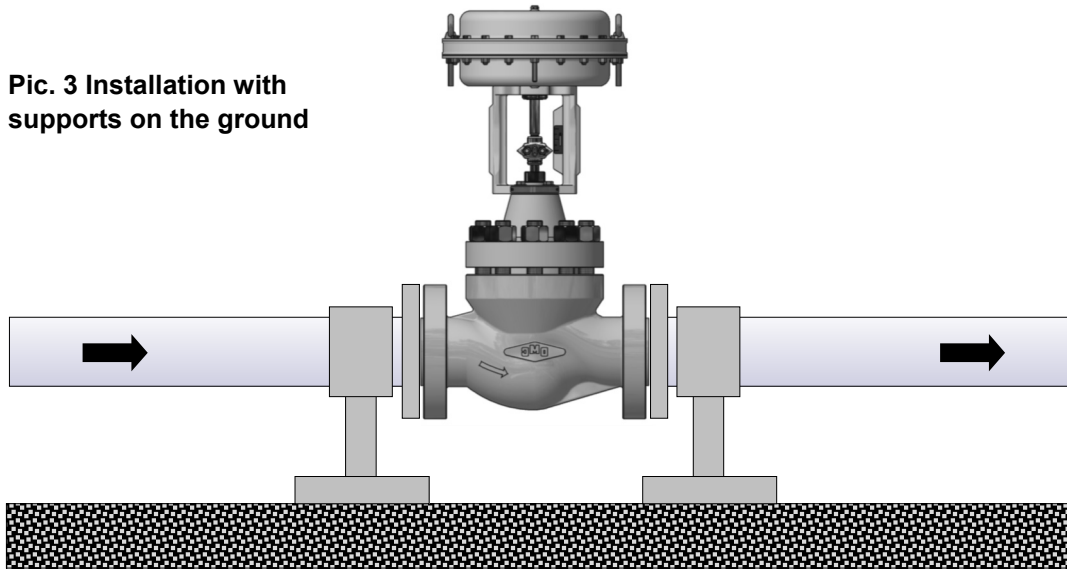

**Pic. 4 Installation with lifting ropes**

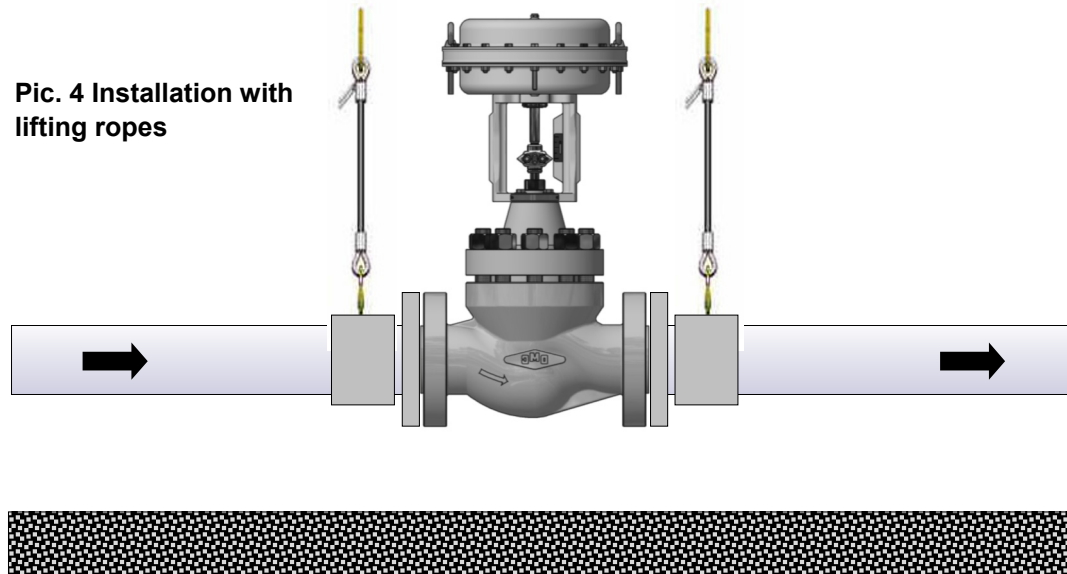

## 3.0 ACTUATOR CONNECTION

### 3.01 PNEUMATIC ACTUATOR CONNECTION

The pneumatic actuator is provided with two 1/4"NPT connections, one of which is closed by a filter. Connect the control air pipe to the connection which has remained free. The control air must be clean, de-humidified and free from oils and greases and must not exceed an allowed maximum pressure. The signal required to control the valve is provided on the plate fixed on the actuator's yoke. If the valve is provided with a pilot positioner, refer to its manual.

For the maintenance operations of the OMC pneumatic actuators, refer to the specific manual.

### 3.02 CONNECTION OF ELECTRIC ACTUATOR

For the connection of the electric actuator refer to its specific manual.

## 4.0 MAINTENANCE

All operations described below must be performed and supervised by skilled, trained and competent personnel. The OMC valves are univocally identified by a serial number fixed on the plate located on the actuator's yoke. To order any spare parts or for any other need, always refer to the above-mentioned number.

**During the operation the valve is pressurized. Before performing any maintenance operation or action on the flanges and closing caps, make sure that the line is depressurized (0 bar) and at ambient temperature.**



### 4.01 VALVE/ACTUATOR SEPARATION

By referring to Pic. 5 (1/2"÷2") or Pic. 6 (for valves 3"÷4") perform the following operations:

- ◆ Set the valve to the 50% stroke
- ◆ Fully unscrew the screws (1) and remove the terminals (2)
- ◆ For valves (1/2" ÷ 2") fully unscrew the ring nut (3).
- ◆ For valves (3" ÷ 4") fully unscrew the screws (4).
- ◆ Remove the actuator.

To re-assemble everything the operations must be performed in the reverse order by paying attention to the alignment of stems and to the value (A)

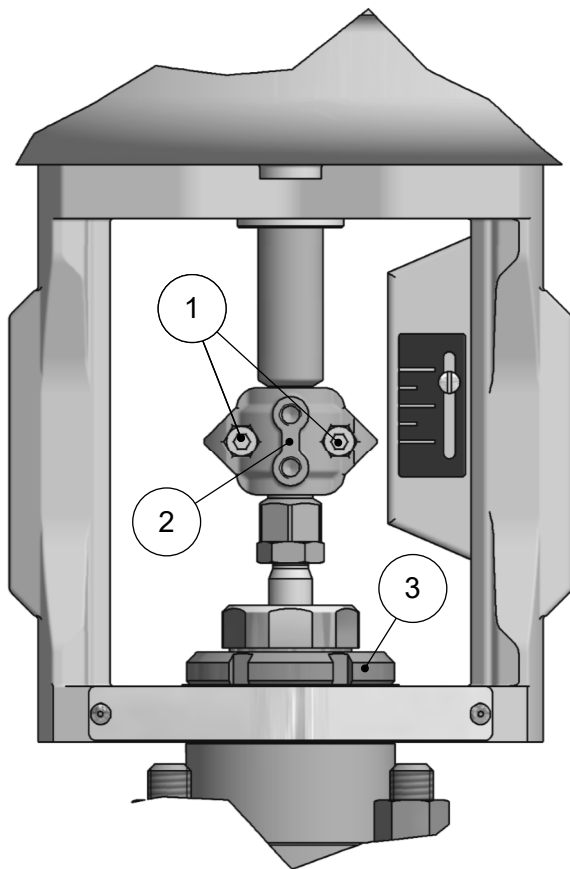

Pic. 5 Valves 1/2" ÷ 2"

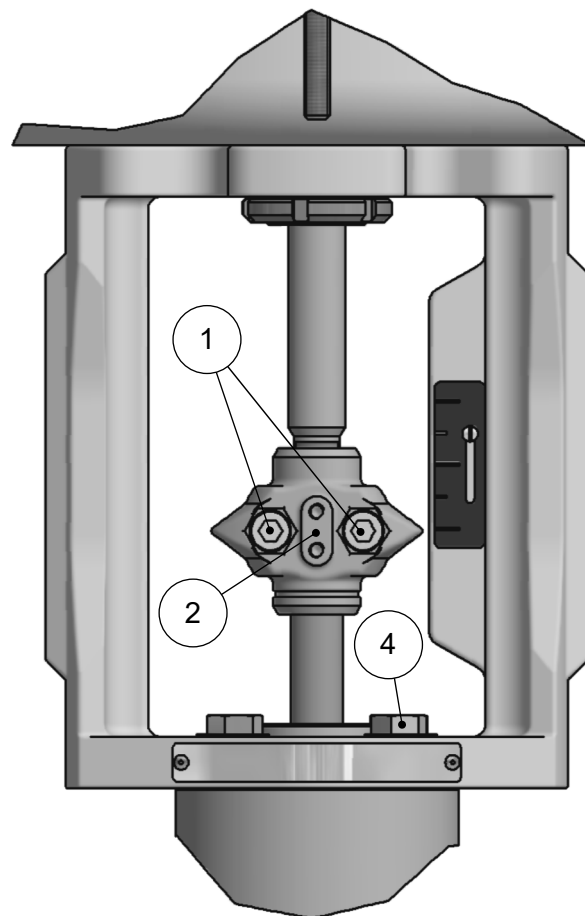

Pic. 6 Valves 3" ÷ 4"

## 4.02 REPLACEMENT OF THE SEAT/PLUG

By referring to Pic. 7 perform the following operations:

- ◆ Separate the actuator from the valve body as described in the previous paragraph
- ◆ Loosen the nut (10) and fully unscrew the bolts (15).
- ◆ Separate the bonnet group (9), the complete plug (3)
- ◆ Remove any cage (5)
- ◆ Replace the sealing gasket of the balancing piston (8) by unscrewing the guide (6).
- ◆ If required, unscrew and replace the seat (2) by using the specific wrenches
- ◆ Insert in the bonnet (9) the new plug by paying attention to grease the stem with the silicone oil.
- ◆ Always replace the body gasket (11) by carefully cleaning the supporting surfaces.
- ◆ Re-assemble everything by repeating the operations in the reverse order by consequently paying attention to the re-alignment of stems, seat and plug.
- ◆ Gradually tighten the nuts (15) in criss-cross sequence, as indicated in the example in Pic.2 paragraph 2.01 by applying the torques indicated in chapter 5

**Attention:** when the plug is being replaced it is required to replace also the packing gland (see next paragraphs).

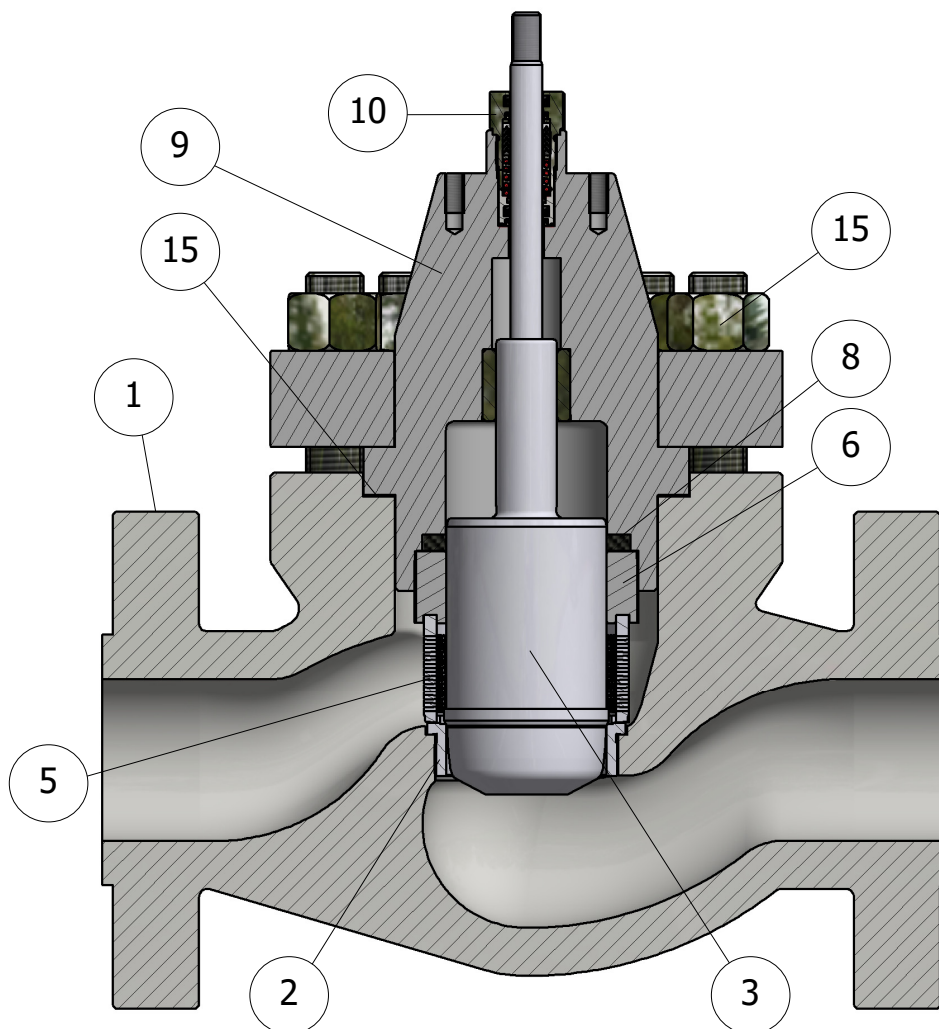

**Pic. 7 Standard valve**



### 4.03 REPLACEMENT OF THE STEM PACKING GLAND

By referring to the picture corresponding to your packing gland model (from Pic.8 to Pic.9) perform the following operations:

- ◆ Remove the plug as described in the previous paragraphs
- ◆ Fully unscrew the screw (1).
- ◆ Remove the upper packing gland (2).
- ◆ Remove the spring (3)
- ◆ Remove the lower packing gland (4).
- ◆ Replace the O-ring (5) if provided
- ◆ Carefully clean the housing chamber and grease it with silicone oil.
- ◆ Insert the new packing gland as shown in the picture corresponding to your model
- ◆ Screw the nut (1) but not completely
- ◆ Insert the plug by paying attention to grease the stem with the silicone oil.
- ◆ Always replace the body gasket, by carefully cleaning the supporting surfaces.
- ◆ Re-assemble everything as described in the previous paragraphs
- ◆ Tighten the nut (1) as indicated in chapter 5

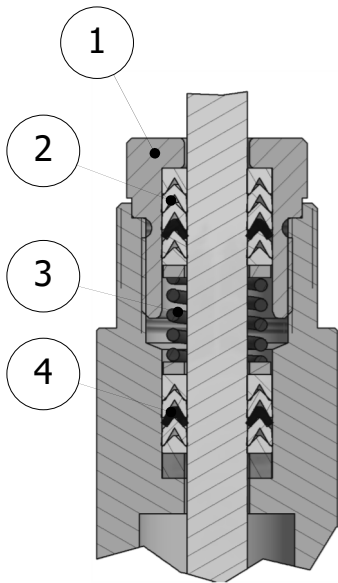

Pic. 8 "LP200"

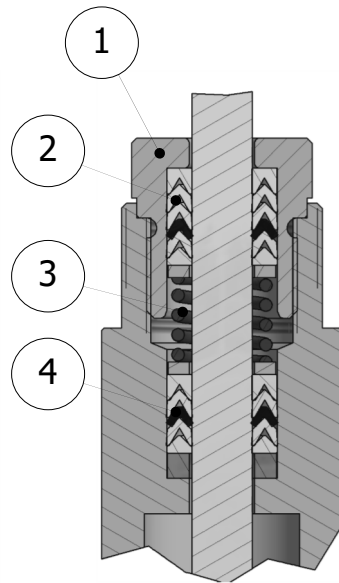

Pic. 9 "SP200"

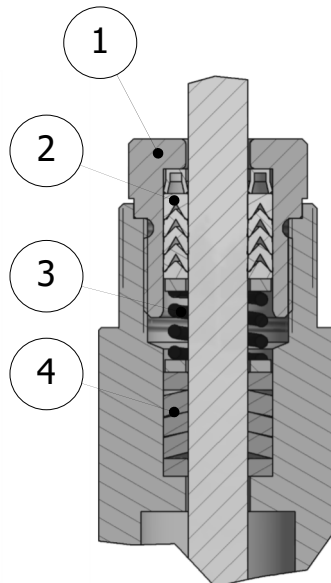

Pic. 10 "HP200"

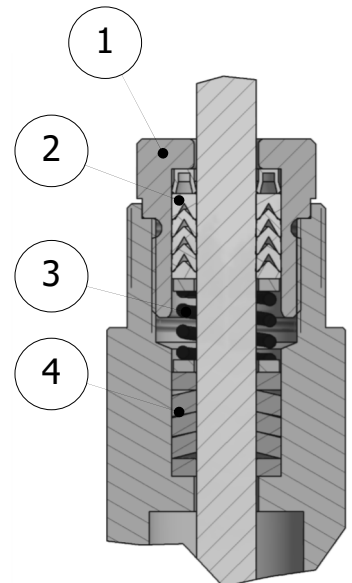

Pic. 11 "EcoPack 1"

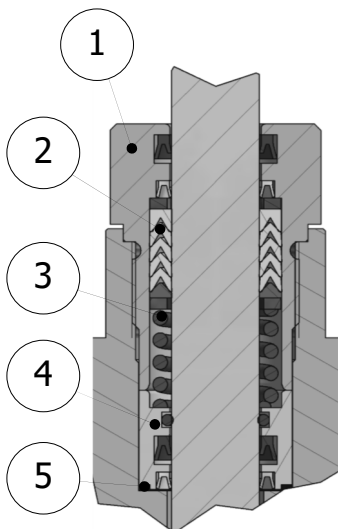

Pic. 12 "LP400"

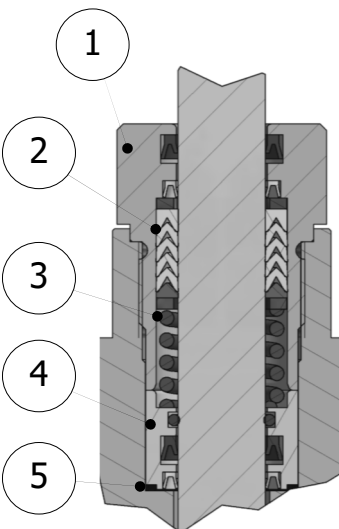

Pic. 13 "SP400"

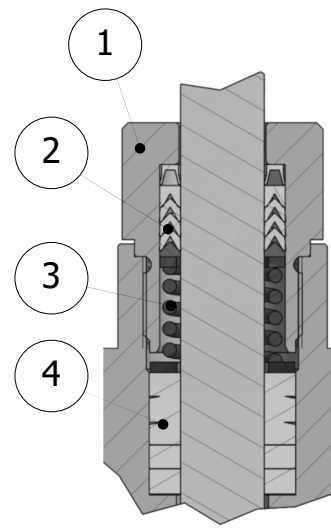

Pic. 14 "HP400"

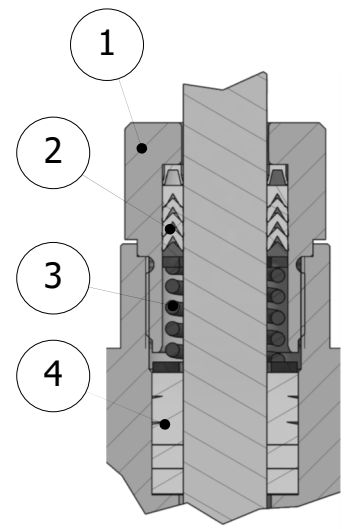

Pic. 15 "EcoPack 2"

## 5.0 TIGHTENING TORQUES

ENGLISH

VALVE DIAMETER	SEAT (1) Nm $\pm 10\%$	BONNET NUTS (2) Nm $\pm 10\%$	NUT (4) Nm $\pm 10\%$
1/2"	190		190
3/4"	190		190
1"	240		190
1" 1/2	550		190
2"	570		190
3"	700		240
4"	850		240

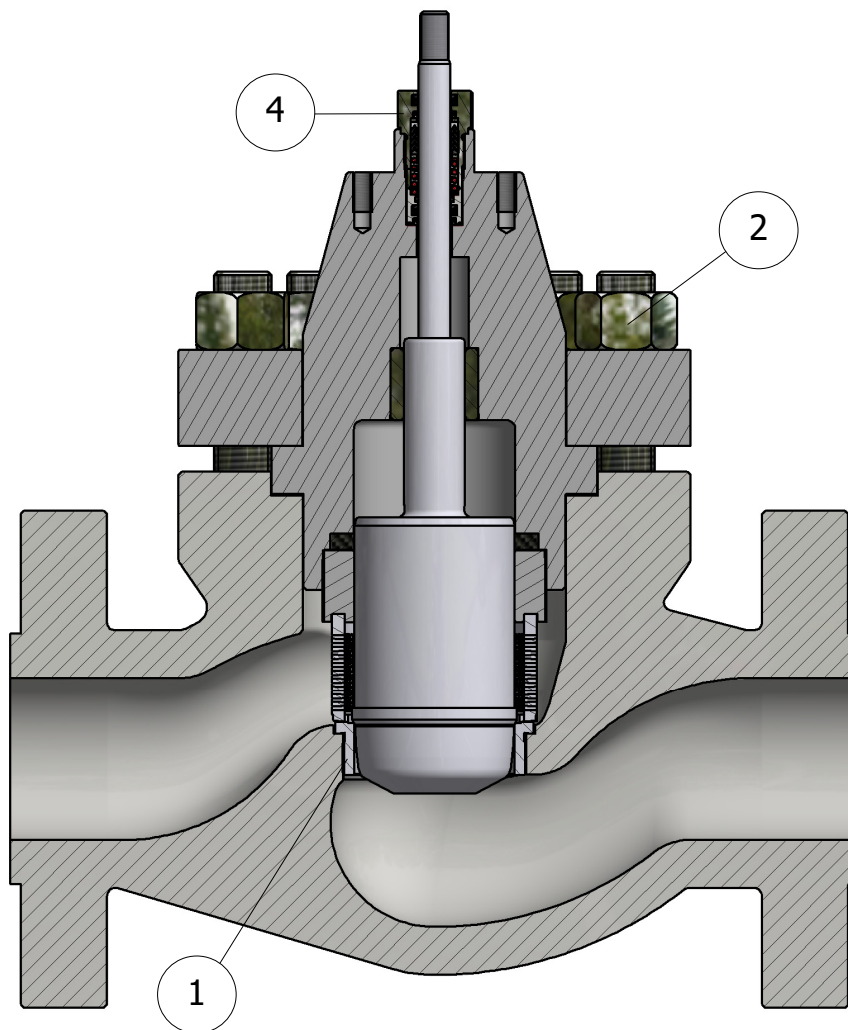

Pic. 16

Our products are manufactured under ISO-9001 Quality Assurance System, approved by CSQ certified under no.9190.OMC2 - FIRST ISSUE 1994/08/04

VALVE DIAMETER	NUTS (9) Nm ±10%	NUT (6) Nm ±10%	RING NUT (7) Nm ±10%	SCREWS (5) Nm ±10%	SCREWS (8) Nm ±10%
1/2"	//	40	480	5	//
3/4"	//	40	480	5	//
1"	//	40	480	5	//
1" 1/2	//	40	480	5	//
2"	//	40	480	5	//
3"	80	//	//	//	50
4"	80	//	//	//	50

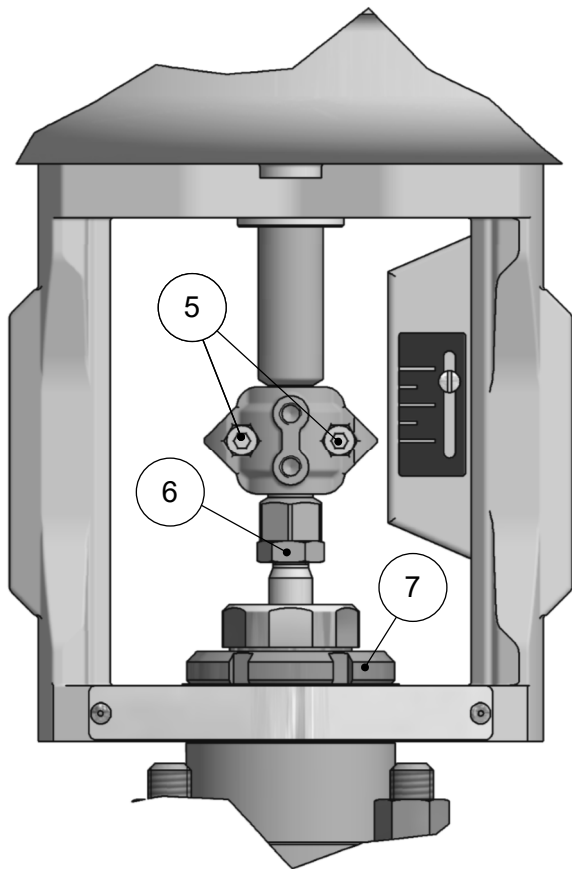

**Pic. 17 Valves 1/2" ÷ 2"**

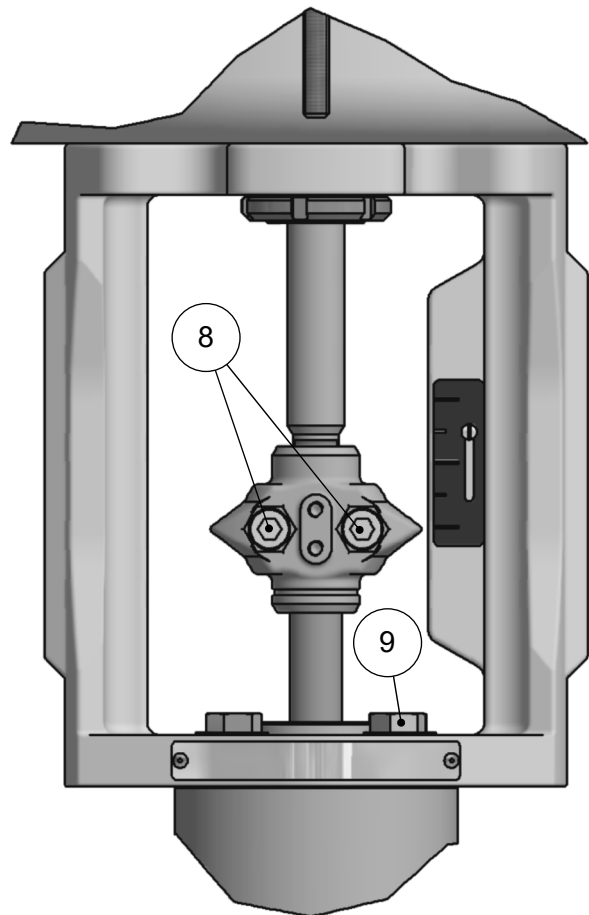

**Pic. 18 Valves 3" ÷ 4"**

## 6.0 SIZES OF THE ACTUATOR CONNECTIONS

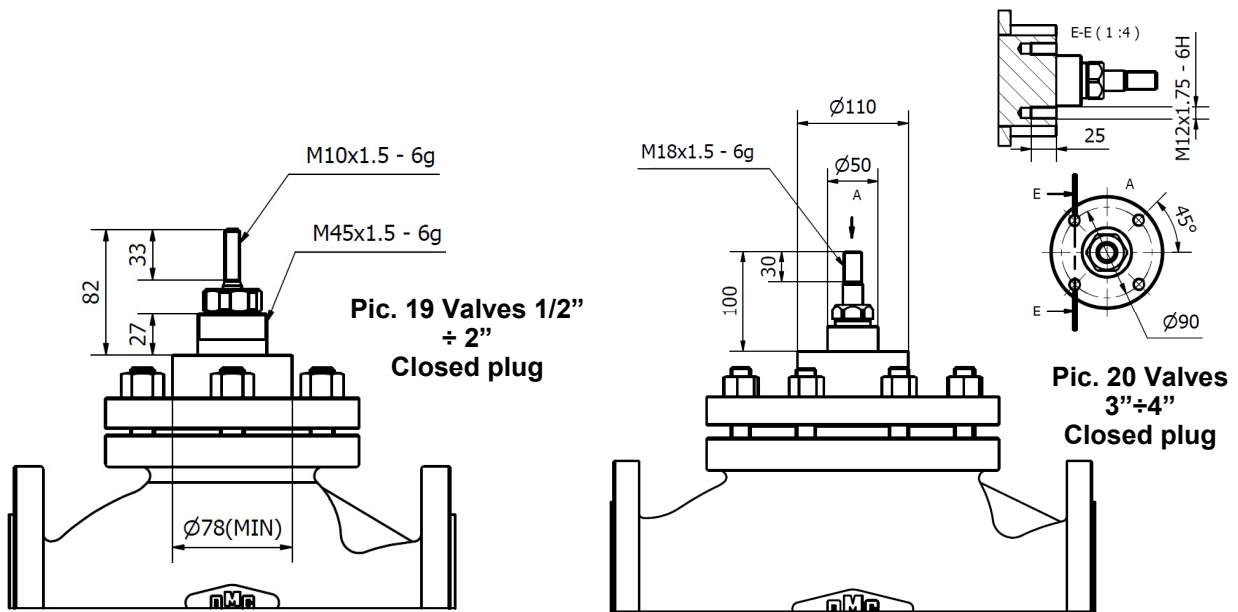

## 7.0 PERIODICAL OPERATIONS

24 hours after the first commissioning, control the connections to the pipe and verify the tightening of the flange bolts. Inspect the valve every year by verifying its wear and replacing any damaged parts.

Periodically verify any phenomena of internal and/or external corrosion and/or erosion as they may significantly damage the pressurized parts by locally reducing the thickness and as a consequence the safety degree.

## 8.0 AVAILABLE SPARE PARTS

DESCRIPTION	PICTURE	POSITION
Seat	7	2
Plug	7	3
Body Gasket	7	11
Sealing gasket of balancing piston	7	8
Stem packing gland	8-9-10-11-12-13-14-15	//



**ATTENTION!!!**The OMC valves are univocally identified by a serial number fixed on the plate located on the actuator's yoke. To order any spare parts or for any other need, always refer to the above-mentioned number.

## 9.0 PRESSURE/TEMPERATURE RELATIONSHIP

For the pressure regression in relation to the temperature refer to the document:

**- OMC-TUV-00**

The actual use of the valve depends on the combination of the materials of which it is made up.